

# AMP1-D8-MDA-3G™ 8 CHANNEL MONITOR WITH DOLBY® AC3



1RU in-rack audio monitor processes encoded, multi-channel audio from Dolby Digital® streams decoded from AES.

The AMP1-D8-MDA-3G monitor is a 1RU in-rack audio monitor capable of outputting and/or displaying encoded, multi-channel audio (up to 8 channels) from Dolby Digital streams decoded from AES. The ability to switch seamlessly between encoded or discrete PCM sources, in addition to providing full, simultaneous demuxed output of the multi-channel source offers a significant new operational capability. The AMP1-D8-MDA-3G monitors audio from Dolby Digital (AC-3), HD-SDI, SD-SDI, AES/EBU, and analog signal sources.

This unit is ideal for use in VTR bays, mobile production vehicles, teleconferencing installations, multimedia systems, satellite links, cable TV facilities, and on-air radio studios. Extended HF response reveals potential problems with audio whine or hiss, and electronic rather than acoustic cancellation of bass frequencies provides positive audible detection of reversed polarity audio feeds. The sleek design provides optimally focused sound for operators in an ultra near field environment (1 to 3 ft.) with performance comparable to that of many separate monitor pairs without installation hassles and awkward speaker placements. This enables a higher SPL for the operator while reducing overall ambient sound and adjacent bay crosstalk.

#### Benefits:

- Supports decoding and playback of Dolby Digital bitstreams
- Select and assign a channel or channel pair to left, right or both speakers, or select a predefined downmix
- 4 presets let you change the entire system configuration with the press of a single button
- Thorough magnetic shielding allows placement next to sensitive equipment and video monitors

#### Features:

- Backlit LED screen displays phase, signal type, Dolby program, and more
- Eight 26-segment tri-color LED bar graphs display simultaneous VU and PPM
- Sum any combination of up to 8 channels to the left and/or right speakers and selected analog outputs
- Premium quality drivers and power amplifiers deliver excellent frequency response and low distortion
- Power 104dB SPL at 2 feet (0.6m)

**ORDER PART #8102-0075 AMP1-D8-MDA-3G**



# AMP1-D8-MDA-3G™ 8 CHANNEL MONITOR WITH DOLBY® AC3

## Rear Panel

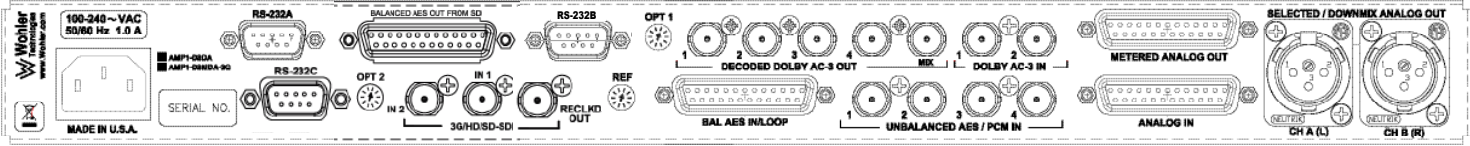

## Block Diagram

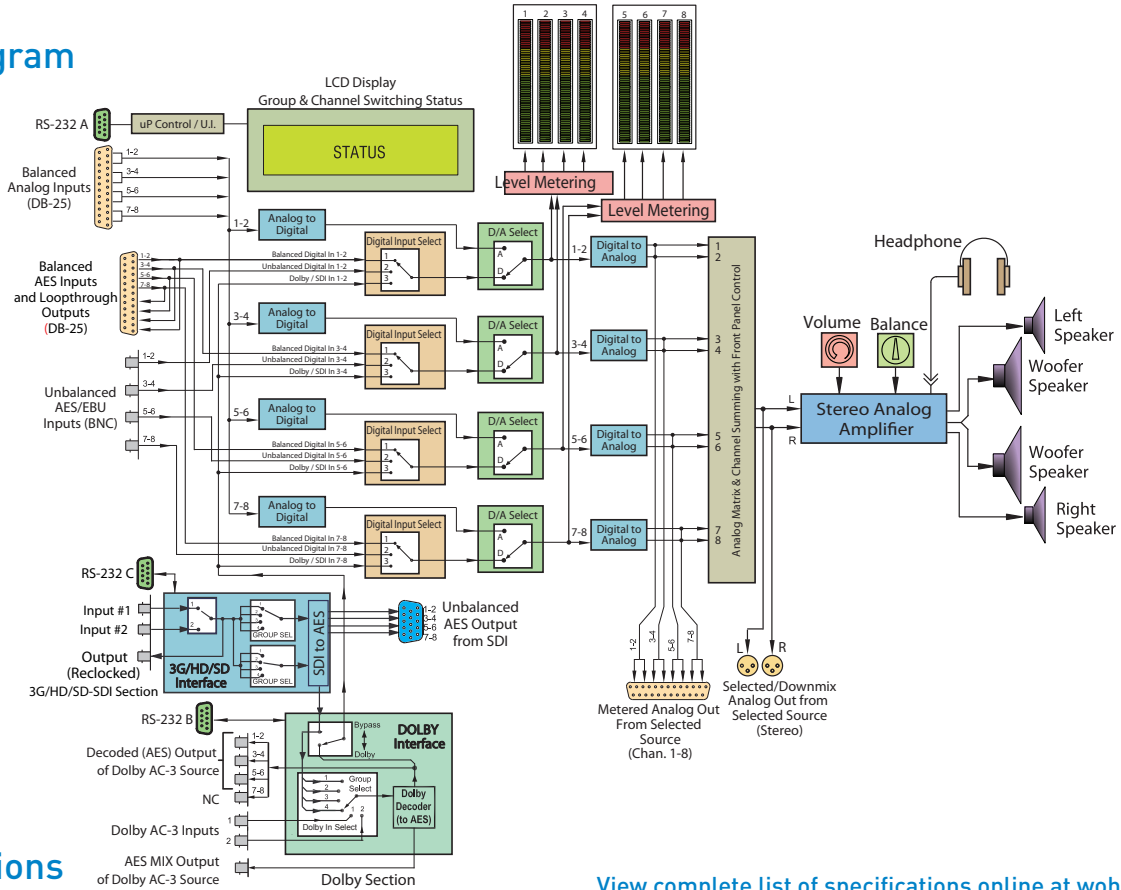

## Specifications

View complete list of specifications online at [wohler.com](http://wohler.com)

Inputs	<ul style="list-style-type: none"> <li>4 Unbalanced AES/PCM pairs (BNC)</li> <li>4 AES Balanced pairs (1 DB-25)</li> <li>2 3G/HD/SD-SDI inputs (BNC)</li> <li>2 Dolby AC-3 (BNC)</li> <li>8 Channels analog (1 DB-25)</li> </ul>
Outputs	<ul style="list-style-type: none"> <li>4 Balanced AES pairs loop out (DB-25)</li> <li>1 3G/HD/SD-SDI relocked output (BNC)</li> <li>4 Decoded Dolby AC-3 (BNC)</li> <li>8 Channels metered analog (1 DB-25)</li> <li>4 Balanced AES outputs from SDI (DB-25)</li> <li>1 Unbalanced AES pair mix out of Dolby source</li> <li>2 Selected downmix analog (2 XLRs)</li> </ul>
Power requirements	100 to 240 VAC ± 10%, 50/60Hz 60 W
Peak acoustic output at 2 feet	104dB SPL