



iAM-MIX

- **iAM-MIX-8**
- **iAM-MIX-8-DA**
- **iAM-MIX-8-SDA**
- **iAM-MIX-8-MADI**
- **iAM-MIX-16**
- **iAM-MIX-16-DA**
- **iAM-MIX-16-SDA**
- **iAM-MIX-16-MADI**

**1RU, 8/16 of 64 Channel, Multi-Source Mixing
Audio Monitor**

User Guide

Part Number 821807, Revision D

© 2017 Wohler Technologies, Inc. All rights reserved.

This publication is protected by federal copyright law. No part of this publication may be copied or distributed, stored in a retrieval system, or translated into any human or computer language in any form or by any means electronic, mechanical, manual, magnetic, or otherwise, or disclosed to third parties without the express written permission of Wohler Technologies.

Reproduction

Licensed users and authorized distributors of Wohler Technologies, Inc. products may copy this document for use with Wohler Technologies, Inc. products provided that the copyright notice above is included in all reproductions.

Customer Support

Wohler Technologies, Inc.
31055 Huntwood Avenue
Hayward, CA 94544
Phone: 510-870-0810
Web: www.wohler.com
Sales: sales@wohler.com
Support: support@wohler.com

Disclaimers

Even though Wohler Technologies, Inc. has tested its equipment and software, and reviewed the documentation, Wohler Technologies, Inc. makes no warranty or representation, either express or implied, with respect to software, documentation, their quality, performance, merchantability, or fitness for a particular purpose.

In no event will Wohler Technologies, Inc. be liable for direct, indirect, special, incidental, or consequential damages resulting from any defect in the hardware, software, or its documentation, even if advised of the possibility of such damages.

Some states do not allow the exclusion or limitation for incidental or consequential damages, so the above exclusion or limitation may not apply to you.

Other Technologies and Products

Google Chrome is a registered trademark of Alphabet Inc. Microsoft Windows and Internet Explorer are registered trademarks of Microsoft Corporation.

Dante and Brooklyn are registered trademarks of Audinate Pty Ltd.

Ravenna is a registered trademark of ALC NetworX GmbH.

Bach is a registered trademark of CoveloZ.

Evertz is a registered trademark of Evertz Microsystems, Ltd.

Grass Valley is a registered trademark of Grass Valley, a Belden brand.

All product names, logos, and brands are property of their respective owners. All company, product and service names used in this document are for identification purposes only. Use of these names, logos, and brands does not imply endorsement.

Last Update

October 4, 2017

TABLE OF CONTENTS

Contents

- User Guide 1
- TABLE OF CONTENTS 3
 - Contents 3
- CHAPTER 1: Installation 5
 - Introduction 5
 - Overview 5
 - Safety 5
 - Instructions 5
 - Safety Symbols 6
 - Mounting 6
 - Heat Dissipation 7
 - Sympathetic Vibration 7
 - Mechanical Bracing 7
 - Electrical Interference 7
 - Power 7
 - Compliance 8
 - FCC 8
 - ICES-003 8
- CHAPTER 2: Local Operation 9
 - Startup 9
 - Front Panel 9
 - Rear Panel 11
 - Channel Displays 14
 - Preset / Config Menu 14
 - Preset Selection 15
 - Product Information 15
 - Set DHCP IP 15
 - Set Static IP Address 15
 - Set Input Source 16
 - Load Preset Configuration from USB Flash Drive 16
 - Factory Reset 17
- CHAPTER 3: Technical Info 18
- CHAPTER 4: Using the iAM-MIX Web GUI 21
 - Web Browser / Control Device 21
 - First Time- IP Assignments 21
 - Peer-to-Peer Connection 21
 - Network Connection 22
 - Dashboard 23
 - Sign In 24

Channel Naming.....	25
Configuration - Setup	26
Configuration – Named Presets	28
Configuration – Device Management.....	29
System Setup	30
Scan Network-Discovery	31
Network Setup.....	32
Database Management	33
Export Configuration.....	33
Import Configuration	34
Save / Restore Database (DB)	35
Factory Reset	36
APPENDIX A: Software Upgrades.....	37
Introduction	37
Download the Software	37
Installing the Software Locally	38
Installing Software on Networked iAM-MIXs.....	39
APPENDIX B: Dante Network Setup	41
Introduction	41
What is in the iAM-MIX for Dante	42
Dante Device Setup.....	43
Dante Clock Selection	44
Channel Names.....	45
AES67	46
Device Lock.....	47
Dante Firmware Upgrades	48
APPENDIX C: Ravenna Network Setup	49
Introduction	49
What is in the iAM-AUDIO for Ravenna.....	49
RAVENNA-compatible talker/listener:.....	49
AVB Ethernet features:	49
BACH™ Controller Graphical User Interface:	50
Home Page.....	51
Patch Panel	52
Controller Cloud.....	53
Source Streams.....	54
Stream Destinations	55
Sync.....	56
Configuration/Device Management	57

CHAPTER 1: Installation

Introduction

Overview

The iAM-MIX intelligent adaptable monitors are 1RU multichannel multi-source audio monitors with multiple standard copper connections and multiple SFP module options facilitating high density coax and optical fiber connections. They feature direct integration capability with Evertz, Tally, and Grass Valley routers for channel name synchronization. The iAM-MIX may also accept Audio over IP signals via an Ethernet connector. Refer to the Specifications section or contact Wohler Sales for more information for Audio over IP capabilities.

The iAM-MIX has individual channel volume controls and mute switches. With certain exceptions related to master clock compatibility, any channel from any source stream may be audibly monitored and mixed with the other selected channels. The iAM-MIX is small, flexible, moderately priced, and simple to operate. Its setup configuration can easily be copied to other iAM-MIX units.

Setups are created with a web browser over a network connection. Each iAM-MIX can be configured with a number of Presets. Nothing about the configurations of those predefined setups can be changed from the front panel. This prevents less experienced or hurried operators from making accidental setup changes that could compromise their usage of the unit. It also reduces operator training to a minimum.

Safety

Instructions

1. Read, keep, and follow all of these instructions; heed all warnings.
2. Do not use this equipment near water.
3. Use only a dry cloth to clean the equipment.
4. Do not block any ventilation openings.
5. Do not install near any heat source such as a radiator, heat register, amplifier, or stove.
6. Do not attempt to plug the unit into a two-blade outlet (with only two prongs of equal width).

Important:

By design, this monitor will only plug into a three-prong outlet for your safety. If the plug does not fit into the outlet, contact an electrician to replace the obsolete outlet.

- 7. Protect the power cord from being walked on or pinched, particularly at plug connection source on the equipment and at the socket.
- 8. Use only the attachments/accessories specified by the manufacturer.
- 9. Unplug the equipment during lightning storms or when unused for long periods of time.
- 10. Refer all servicing to qualified service personnel. Servicing will be required under all of the following conditions:
 - a. The equipment has been damaged in any way, such as when the power-supply cord or plug is damaged.
 - b. Liquid had been spilled or objects have fallen onto the equipment.
 - c. The equipment has been exposed to rain or moisture.
 - d. The equipment does not operate normally.
 - e. The equipment has been dropped.

Safety Symbols

WARNING:

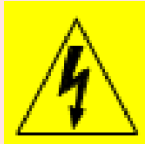

The symbol to the left warns of electric shock hazard inside the unit. Disconnect the power cord before removing access panels when installing upgrades. Only qualified service personnel are to operate the equipment with covers removed, and are to exercise caution to avoid personal injury.

Mounting

The unit is designed for a standard 19" rack. Install it at ear/eye level for best high frequency response and visual observation of the display screens. Please adhere to the following clearances:

Table 1-1: Clearance Recommendations

Clearance	Surface
24"	Front
3"	Rear
2"	Sides
1.75"	Top and Bottom (if either radiates heat)
0"	Top and Bottom (if no heat)

Heat Dissipation

The ambient temperature inside the mounting enclosure should not exceed 40° Celsius (104° Fahrenheit). Adjacent devices can be rack mounted (or stacked) in proximity to the unit if this temperature is not exceeded. Otherwise, allow a 1RU (1.75"/44.45mm) space above and below the unit for air circulation.

Important

Heat generated by the class D power amplifiers, power supplies, and other components is vented by slots in the sides and back of the unit. Therefore, as a safety precaution, you must allow proper ventilation on these surfaces.

Sympathetic Vibration

Sympathetic vibration from other equipment (cables, etc.) in the rack may be serious enough to interfere with the unit's sound quality. If you experience sympathetic vibrations, use thin card stock, felt, foam, or weather-stripping between the vibrating surfaces. Tie loose cables securely with cable ties.

Mechanical Bracing

The 1RU chassis is securely attached to the front panel. In addition, the chassis has mounting tabs through which you attach it to the rack rail. This feature will reduce or eliminate rear bracing requirements in many mobile/portable applications. The weight of internal components is distributed fairly evenly around the unit.

Electrical Interference

Be careful to avoid mismatched cable types and other similar causes of undesired reflections in digital signal systems. If severe enough, such reflections can result in corruption of the digital data stream. As with any audio equipment, maximum immunity from electrical interference requires the use of shielded cable; however, satisfactory results can sometimes be obtained without it. The internal circuitry ground is connected to the chassis.

Power

The unit comes with a standard 18 VDC / 3.9 A external power supply that connects to an AC mains power source (100 to 240 VAC, 1.5A, 50/60Hz) using an IEC power cord.

When the mains plug or appliance coupler is used as the disconnect device, the disconnect device should remain operable.

Compliance

FCC

This equipment has been tested and found to comply with the limits for a Class A digital device, pursuant to part 15 of the FCC Rules. These limits are designed to provide reasonable protection against harmful interference when the equipment is operated in a commercial environment. This equipment generates, uses, and can radiate radio frequency energy and, if not installed and used in accordance with the instruction manual, may cause harmful interference to radio communications. Operation of this equipment in a residential area is likely to cause harmful interference, in which case the user will be required to correct the interference at their own expense.

ICES-003

This Class A digital apparatus complies with Canadian ICES-003.

Cet appareil numérique de la classe A est conforme à la norme NMB-003 du Canada.

CHAPTER 2: Local Operation

Startup

The iAM-MIX-8 and iAM-MIX-16 units (and their variants) take about a minute to become operational after power is applied. During that time, several status messages are shown spanning the displays on the front panel.

Front Panel

The iAM-MIX-8 front panel is shown in Figure 2-1. The iAM-MIX-16 front panel is shown in Figure 2-2.

Figure 2–1: iAM-MIX-8 Front Panel

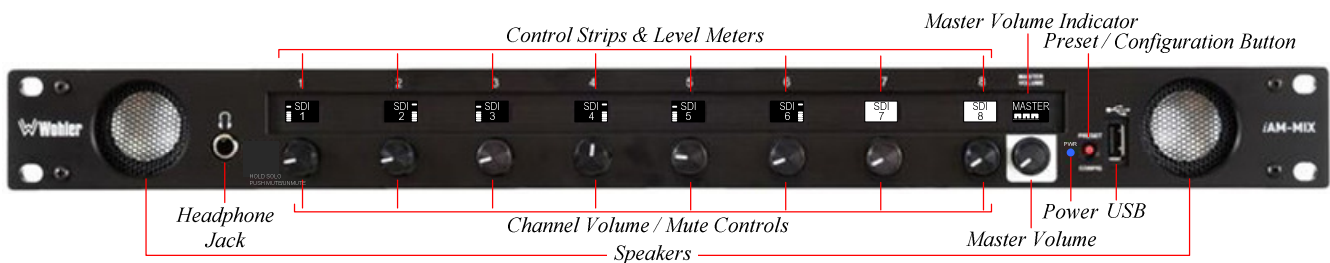
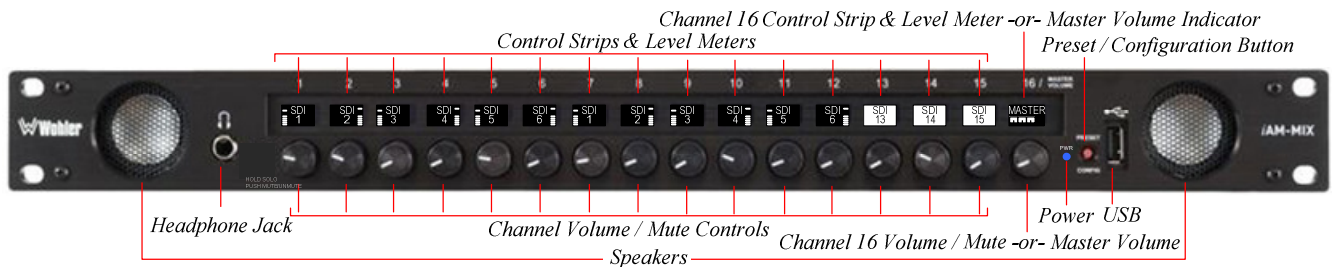

Figure 2–2: iAM-MIX-16 Front Panel



Important:

The number (1-8 or 1-16) above the channel control strips does not indicate any particular source channel number or arrangement. Strip numbers only serve as references for channel configurations at the iAM-MIX Web GUI level. Different Presets typically have different channel numbers assigned to control strips.

The audio mixer terminology of “strips” is used in this manual when referring to the identification of the controls. The control strip display label default is to display the input type and channel number, but may be changed in the

iAM-MIX Web GUI to show any displayable text or numbers.

1. **Speakers:** Audio monitoring is achieved through the use of class D amplifiers driving two (left/right) wide range speakers.
2. **Headphone Jack:** A 1/4" jack for an optional headphone is provided on the front panel. Speaker audio mutes when headphones are plugged in.
3. **Channel Volume/Mute:** Rotating each **Channel Volume/Mute** control adjusts the individual level of each corresponding channel. Pressing this control knob alternately mutes or unmutes the associated channel. Holding the control knob pressed for two seconds solos the associated channel and mutes all others.
4. **Master Volume:** This control adjusts the level of the entire mix. Note that while there is a dedicated **Master Volume** control on the iAM-MIX-8, the iAM-MIX-16 incorporates a control that can be set up to be either a **Master Volume** control or a 16th **Channel Volume/Mute** control. Pressing a Master Volume control alternately mutes or unmutes the entire mix.
5. **Control Strips and Level Meters:** These miniature displays identify each **Channel Volume/Mute** control and provide a basic 10-segment level meter for each channel. Refer to the **Channel Displays** section of this chapter for further information on the functions of the **Control Strips and Level Meters**.
6. **Preset/Config Button:** Pressing this button activates a menu for Preset selection and configuration status information. Refer to the **Preset/Config Menu** section of this chapter for a description of how to use this button.
7. **USB:** This USB 2.0 Type A connector allows you to use a flash drive (not supplied) to perform software updates or copy system configurations to another iAM-MIX or to a PC.
8. **Power Indicator:** The **Power** indicator lights blue whenever the iAM-MIX is connected to power.

Rear Panel

The iAM-MIX-8 and iAM-MIX-16 rear panels are shown in Figure 2-3. They are identical. Some variants may not have all options stuffed (e.g. the MADI only unit).

Figure 2-3: Rear Panel Layout

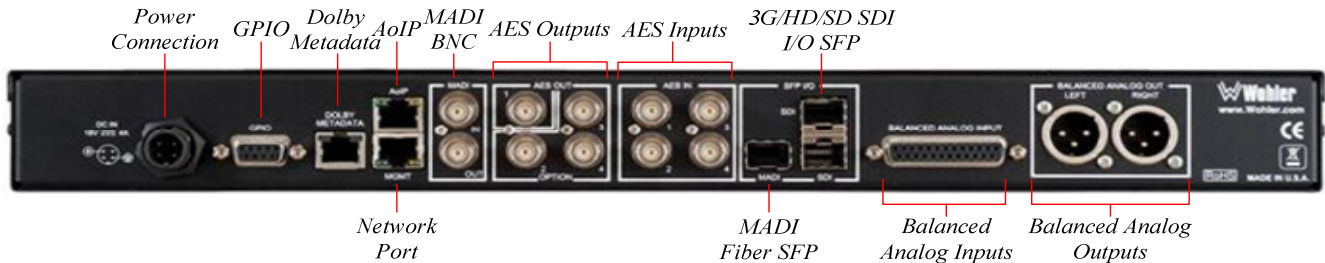

1. **Power Connection:** The iAM-MIX uses an external AC to 18V DC power adapter. The AC inlet of the adapter is a standard IEC receptacle for 100 to 240 VAC $\pm 10\%$, 50/60 Hz power connection. Four regional AC power cords, supplied per shipping region, are available.

Important:

By design, the supplied AC mains power cord will only plug into a three-prong grounded outlet for your safety. If the plug does not fit into the outlet, contact an electrician to replace the obsolete outlet.

Important:

The monitor and power adapter have been tested as a combined apparatus to verify compliance with applicable safety and electromagnetic compliance standards. Use of another power adapter provided by the user may negate the compliance or cause the monitor to not perform properly. Wohler Technologies cannot accept any responsibility for the outcome in such cases.

2. **GPIO:** (future implementation) This DB-9 connector provides 2 input pins and 2 output pins to perform GPIO functions as defined by the iAM-MIX Web GUI.
3. **Network Port:** This Ethernet port can connect to either a LAN or to a PC to let you customize the iAM-MIX configuration. It will also allow you to copy system configurations from one iAM-MIX to another. It can also be used to update the iAM-MIX software and firmware.
4. **AoIP:** This Ethernet port can accept either a Dante or a Ravenna Audio over IP signal. There are different hardware option cards for

each signal and the appropriate/desired capability must be specified at order.

5. **MADI BNC:** This COAX input accepts an AES10 64-channel signal at 48 kHz sample rate. The COAX output is reclocked from the MADI source. When power to the iAM-MIX is not present, the COAX input and output are automatically connected together to allow the MADI signal to pass through.
6. **MADI Fiber SFP:** (optional) This input module accepts an optical AES10 64-channel MADI input signal at 48 kHz sample rate. The SFP fiber module may be used in conjunction with the MADI BNC connectors to provide COAX to fiber or fiber to COAX conversion. The outputs are reclocked. A software license must be installed for the SFP port to function. Refer to the **System Setup** section in Chapter 4 and to Figure 4-8 to install software licenses.
7. **Dolby Metadata:** This RJ-45 jack transmits metadata from the selected Dolby bitstream in RS-485 serial data protocol.
8. **AES Out:** By default, the BNC AES-1 jack outputs the same mixed audio as the XLR analog outputs, as heard from speakers or headphones, but as an AES3id pair. Other options may be set in the iAM-MIX Web GUI. AES 2-4 jacks are reserved for possible future implementation.
9. **AES In:** These four BNC jacks accept AES3id digital audio pairs at 48 kHz sample rate. Channels are selected as AES 1-8.
10. **3G/HD/SD-SDI:** The two cages provided accept one or two optional SFP modules compatible with SDI coaxial or optical signals. Single or dual transceiver arrangements are possible. A software license must be installed for an SFP port to function. Refer to the **System Setup** section in Chapter 4 and to Figure 4-8 to install software licenses.
11. **Analog Inputs:** This DB-25 female connectors accepts +10dBu broadcast level balanced audio. Tascam pinout cables may be used, and can be purchased Wohler Sales. Refer to Figure 2-4 for the pinout of this connector.

Figure 2-4: Analog DB25 Input Connections

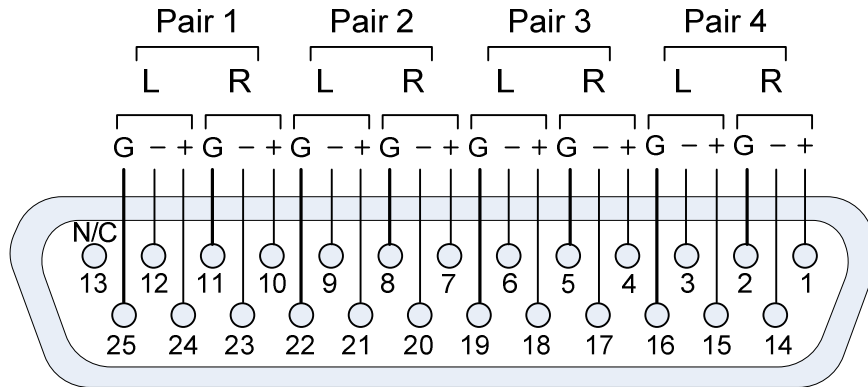

12. **Analog Outputs:** These male XLR connectors provide two balanced analog outputs: **Left** and **Right**. The source of these signals is the mix of audio as monitored by the internal speakers.

Figure 2-5: Analog XLR Output Connections

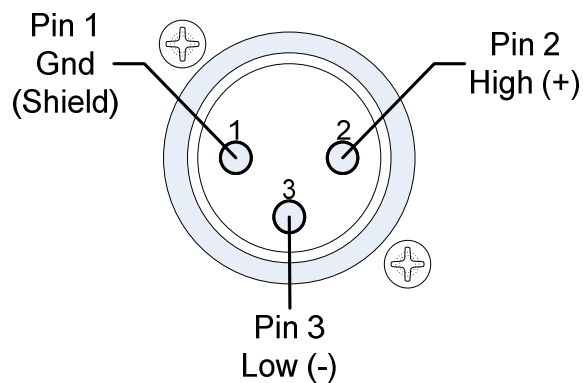

Channel Displays

Display information for each channel strip is shown in Figure 2-6 below.

Figure 2-6: Strip-Channel Display

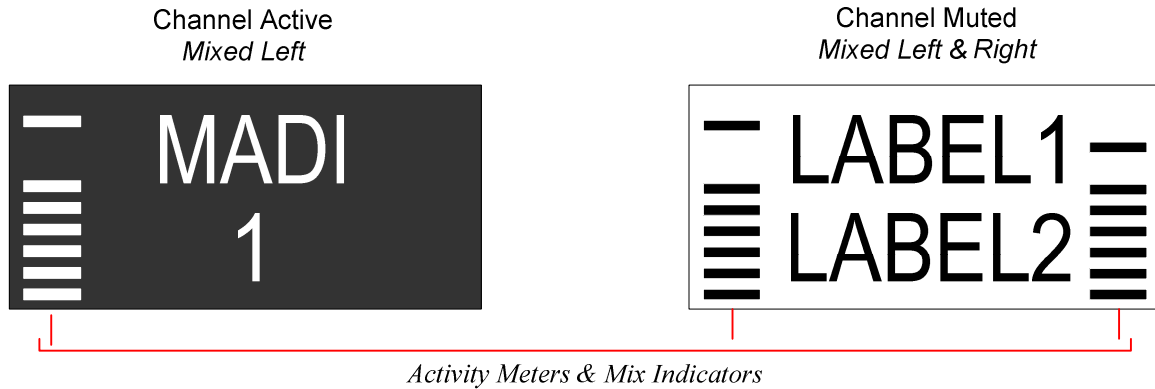

1. **Activity Meters:** The activity of the 10-segment bargraph meters provides a quick indication of signal presence. A floating peak bar above an average level stacked bar is also shown. The meter left/right position(s) indicates left/right Mix Assignments. Both left and right meters are displayed when a mono source channel is being sent to both sides of the speakers, headphones and outputs.
2. **Mute:** When a channel is muted, the entire display is inverted for reverse video, so that it will have a white background with black labels and meters.
3. **Strip Labels:** Two lines of text can be used to identify the audio source by name, channel number, or other information. Evertz, Tally, or Grass Valley integration can be used to automatically fill in these labels. Refer to the **Configuration - Device Management** section of Chapter 4.
 - a. Five or six upper case letters or numbers will typically fit on each line. Since text character widths vary, the exact number of characters displayed can vary. The right edge may get cut off if very wide characters are entered.
 - b. Lower case text characters are displayed as smaller capital letters (small caps) to allow more characters to be displayed.

Preset / Config Menu

Operators can select between up to 8 Presets or access several control or informational screens by pressing the **PRESET / CONFIG** button on the front panel. It is recessed to prevent accidental activation. When the button is pressed, the menu shown in Figure 2-7 appears. Figure 2-7 depicts the

menu as it appears on an iAM-MIX-8. The menu on the iAM-MIX-16 is very similar. If the **PRESET / CONFIG** button is accidentally pressed, pressing **EXIT MENU** will exit the menu and return to normal monitor operation, unchanged. It takes about 3 seconds to exit this or any other menu.

Figure 2-7 Preset / Config Menu



The following describes the function and operation of each menu control shown in Figure 2-7:

Preset Selection

Pressing the control directly below **SELECT PRESET** will display all the available Presets by name. The current Preset will be highlighted in reverse video. Press it to exit the menu with no changes. To select a new Preset, press the control corresponding to the name of the Preset you choose. It will take approximately 3 seconds to recall the Preset, and then the Channel Strip will return to its normal indications.

Product Information

Pressing **SHOW INFO** shows the software revision and serial number. It also shows the static IPv4 address currently set. Press **EXIT MENU** to return to normal monitor operation when you are finished reading this information.

Set DHCP IP

Press **SET IP DHCP** to change the IP address mode to DHCP. A menu will appear offering the choice of **REBOOT DHCP** or **CANCEL No CHG**. Press **CANCEL No CHG** or **EXIT MENU** to exit this menu with no IP address changes or press **REBOOT DHCP** to change the IP address mode to DHCP and reboot the iAM-MIX.

Set Static IP Address

Press **SET IP STATIC** to change the IP address mode to Static and then enter a new static IP address. To change the network address, use the following steps:

1. Rotate the leftmost **ADDR <TYPE>** knob so that it says **ADDR**. The upper characters of the next four knobs will show the current IP address or last saved address.
2. Rotate each of the next four knobs to select the new address. The newly entered address will appear on the lower characters of these knobs, while the current address will still appear on the upper

characters for your reference. When finished entering the address, press **SAVE CHANGE**.

3. Rotate the leftmost knob so that it says **MASK**. The upper characters of the next four knobs will show the current mask.
4. Rotate each of the next four knobs to select the new mask. The newly entered mask will appear on the lower characters of these knobs, while the current mask will still appear on the upper characters for your reference. When finished entering the mask, press **SAVE CHANGE**.
5. Rotate the leftmost knob so that it says **GTWY**. The upper characters of the next four knobs will show the current gateway.
6. Rotate each of the next four knobs to select the new gateway. The newly entered gateway will appear on the lower characters of these knobs, while the current gateway will still appear on the upper characters for your reference. When finished entering the gateway, press **SAVE CHANGE**.
7. Rotate the leftmost knob so that it says **DNS**. The upper characters of the next four knobs will show the current DNS.
8. Rotate each of the next four knobs to select the new DNS. The newly entered DNS will appear on the lower characters of these knobs, while the current DNS will still appear on the upper characters for your reference. When finished entering the DNS, press **SAVE CHANGE**.

At this point, you may rotate the leftmost knob to review or possibly correct any of the address entries you have made. To apply the changes you have made, press **REBOOT NEWADR**. The iAM-MIX will reboot with the new address.

To exit and cancel the changes you have made, press **EXIT MENU**.

Set Input Source

Press **SET INP SOURCE** to select the input source you would like to monitor from among the licensed inputs. Press one of the choices given. Another menu may appear to allow you to select from among the inputs of your chosen source.

To exit without selecting a different input source, press **EXIT MENU**.

Load Preset Configuration from USB Flash Drive

iAM-MIX configurations can be saved to a USB flash drive from the Web GUI. This allows you to easily set up several iAM-MIX units exactly the same way. Press **GETUSB CONFIGS** to load a new system configuration that you have saved on a USB flash drive. Two choices appear: **Rd USB No** and **Rd USB Yes**. Insert a USB flash drive with a system configuration file on it and press **Rd USB Yes**. Further choices will appear to allow you to select the new configuration. If there is no USB flash drive inserted or if no configuration file can be found, an error message appears and the menu exits.

If you would like to exit the menu, press **Rd USB No** or **EXIT MENU**.

Factory Reset

It can be useful to bring all of the settings of the iAM-MIX back to the way they were when it left the Wohler factory if the iAM-MIX is being reinstalled at a new location. Press **FACTORY RESET** to begin the process. The choices **MFG No?** and **RESET YES?** appear.

To continue with the factory reset, press **RESET YES?** The iAM-MIX will reboot with its original settings.

To cancel the reset process, press **MFG No?** or press **EXIT MENU**.

CHAPTER 3: Technical Info

Table 3–1: iAM-MIX Specifications

Specification	Values/Domains
Power Requirements	100 V to 240 V AC \pm 10%, 50/60Hz
Power Consumption	40 Watts
Dimensions (H x W x D)	1.75" x 19" x 7.5" (44mm x 483mm x 191mm)
Weight	8 lbs. (3.6 kg)
Supplied Accessories	Power Adapter, AC Power Cord
Display Type	Passive Matrix OLED
Number of Displays	9 or 16
Screen Resolution	64H x 32V
Sample Rate	48kHz
De-Multiplexing	16 channels from: <ul style="list-style-type: none"> • 16-channel SD/HD/3G-SDI • 64-channel AES10 MADI
SDI Inputs / Outputs	<ul style="list-style-type: none"> • 1 or 2 SDI Inputs or Outputs Optional – Single SFP Transceiver: <ul style="list-style-type: none"> • HD-BNC Coax 3G/HD/SD-SDI • Multi-Mode Fiber: 1 SI Optical SC-Connector, 1300nm • Single-Mode Fiber: 1 SI Optical SC Connector, 1310nm
MADI Inputs / Outputs	<ul style="list-style-type: none"> • 1 MADI BNC, Standard Coax I/O Optional – SFP Transceiver: <ul style="list-style-type: none"> • Multi-Mode Fiber: 1 MADI Optical SC-Connector, 1300nm • Single-Mode Fiber: 1 MADI Optical SC Connector, 1310nm
Analog Inputs / Outputs	<ul style="list-style-type: none"> • 8 Balanced Analog Inputs on DB-25 are standard with every unit. • 2 Balanced Analog Outputs of monitored signal on XLR are standard with every unit.
AES Inputs / Outputs	<ul style="list-style-type: none"> • Inputs: 8 AES channels on 4 BNC are optional • Output: 2 AES channels of monitored signal on 1 BNC is optional
Audio over IP Input / Output	Ethernet AoIP I/O accepts either an optional <ul style="list-style-type: none"> • Dante/AES67 capable signal, or • Ravenna/AES67 signal
Cable/Fiber Length (max)	COAX (such as Belden 1694A): > 150 m
	Multi-mode fiber: 1 km
	Single-mode fiber: 10 km

Specification	Values/Domains
SDI Input Termination	75Ω unbalanced
AES/EBU Input Termination	75Ω unbalanced
Analog Input Impedance	40kΩ balanced
AES/EBU/MADI Sampling Rate	48 kHz
Analog Outputs-Stereo	XLR-3 Male, balanced +24dBu max
Analog Output Frequency Response	40 Hz to 20 kHz (\pm 1dB)
Analog Output Distortion	<0.01% THD+N
Analog Output Dynamic Range	>100 dB
Analog Output Reference Level	-20 dBFS = +4 \pm 1.0 dBu
Internal Speakers - Stereo	40mm Full Range
Peak Acoustic Output	90dBA SPL (@ 2 feet)
Power Output	4 Watts RMS, 8 Watts peak (each side)
Acoustic Frequency Response	150 Hz to 16 kHz (\pm 5 dB)
Headphone Out - Stereo	40 Hz to 20 kHz (\pm 1dB)
Headphone Load	8Ω to 150Ω

Figure 3–1: iAM-MIX Block Diagram

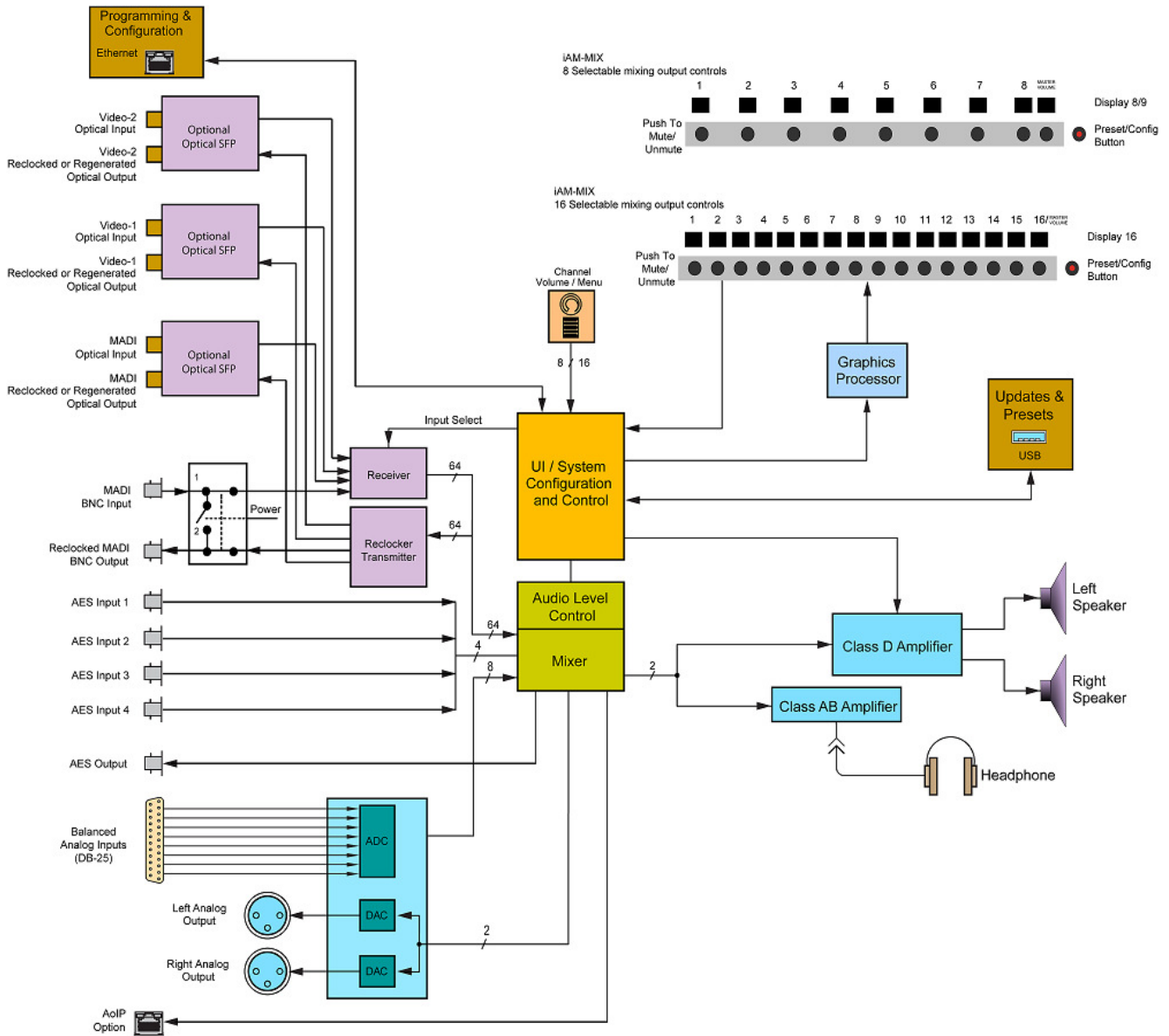

CHAPTER 4: Using the iAM-MIX Web GUI

The iAM-MIX Web GUI allows you to customize the monitor's configuration to suit your needs. The default Presets configure the channels of each source in a consecutive fashion. If the default configuration of the iAM-MIX suits your needs and you prefer to use it that way, then you do not need to use the iAM-MIX Web GUI.

Web Browser / Control Device

Any web browser application running on any networked device such as desktop or laptop computer, tablet or smart phone can be used with the iAM-MIX Web GUI.

Tablets would need to be linked to a copper LAN through a Wi-Fi adapter if the tablet has no network connector.

Phones are not recommended due to their smaller screen size that will require more scrolling.

The Chrome[®] web browser is recommended for speed and compatibility.

First Time- IP Assignments

The iAM-MIX can operate with a static (fixed) or dynamic (DHCP) IPv4 address. The address will be **172.27.2.2** when received from the factory or when switched from DHCP to static addressing mode. There are two basic types of connections that may be used to connect the iAM-MIX to a web browser, a **Peer-to-Peer Connection** or a **Network Connection**.

Peer-to-Peer Connection

The most straightforward way to connect the iAM-MIX to a web browser, free of possible network conflicts, is to establish a static peer-to-peer connection between the setup computer and the iAM-MIX. A 10/100/1000 MHz Ethernet switch may be used in between, but is not required.

Figure 4-1 shows an example of suitable address settings for the host computer in a Windows 7 control panel.

Figure 4–1: Host IP Settings

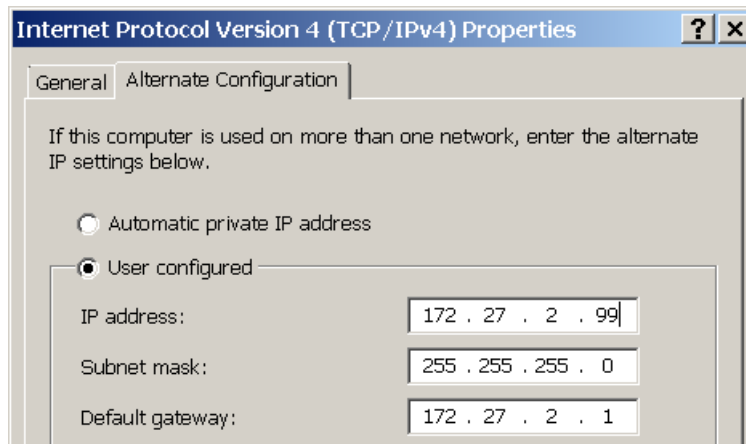

Close the control panel and reboot the host computer after making an IP address change to be sure the change takes effect. **Either reconnect to the installed network or continue with this direct connection to access the iAM-MIX Web GUI.**

Network Connection

When connected to a network, the iAM-MIX address will need to be changed to another address in order to be compatible with the address assignments for that particular network. Immediately after the host setup is complete, change the address of the iAM-MIX. Make the corresponding address, mask and gateway changes in the iAM-MIX **Network Setup** page. Refer to the **Network Setup** section of this chapter and Figure 4-11.

Otherwise set the iAM-MIX to DHCP address mode by checking the box for 'Use DHCP?' in [Network Setup](#) and have your IT administrator assign rights and settings for operation on the network. Allow enough time for your network's DHCP server to recognize a new network device and assign an address after booting.

Dashboard

Throughout the iAM-MIX Web GUI, other pages are a click or two away on the left side. System Overview on this Dashboard page shows all Preset configurations at a glance.

Figure 4–2: Dashboard Preset Overview

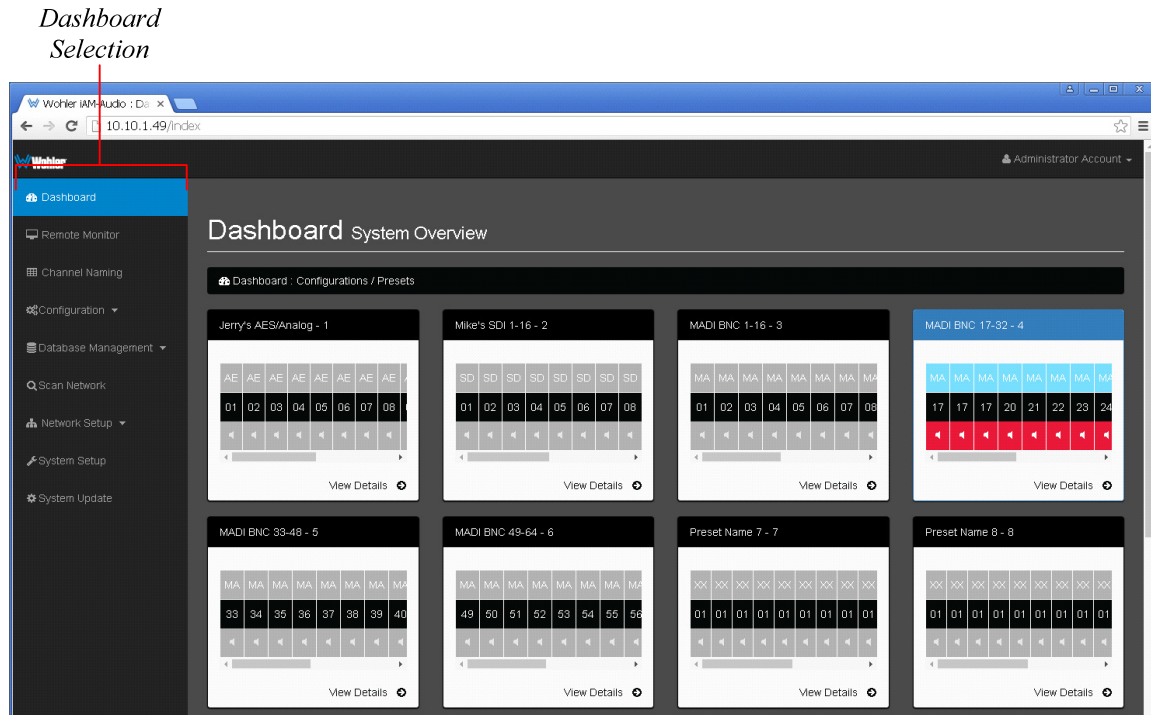

The currently selected Preset for local operation is shown full color. Other stored, but not selected, Presets have gray backgrounds.

The top row shows which sources are used in the Preset. The middle row shows which channel numbers are assigned to each control strip. Colors in the bottom row indicate green for active, or red for muted states.

No changes can be made on this screen. Click **View Details** on the selected Preset, or click on **Configuration - Presets Management** in the left navigation pane to make Preset changes.

The lower part of the page shows front and rear panels for setup reference, plus alerts, status and license information. Refer to Figure 4-3.

Figure 4–3: Dashboard Device Overview

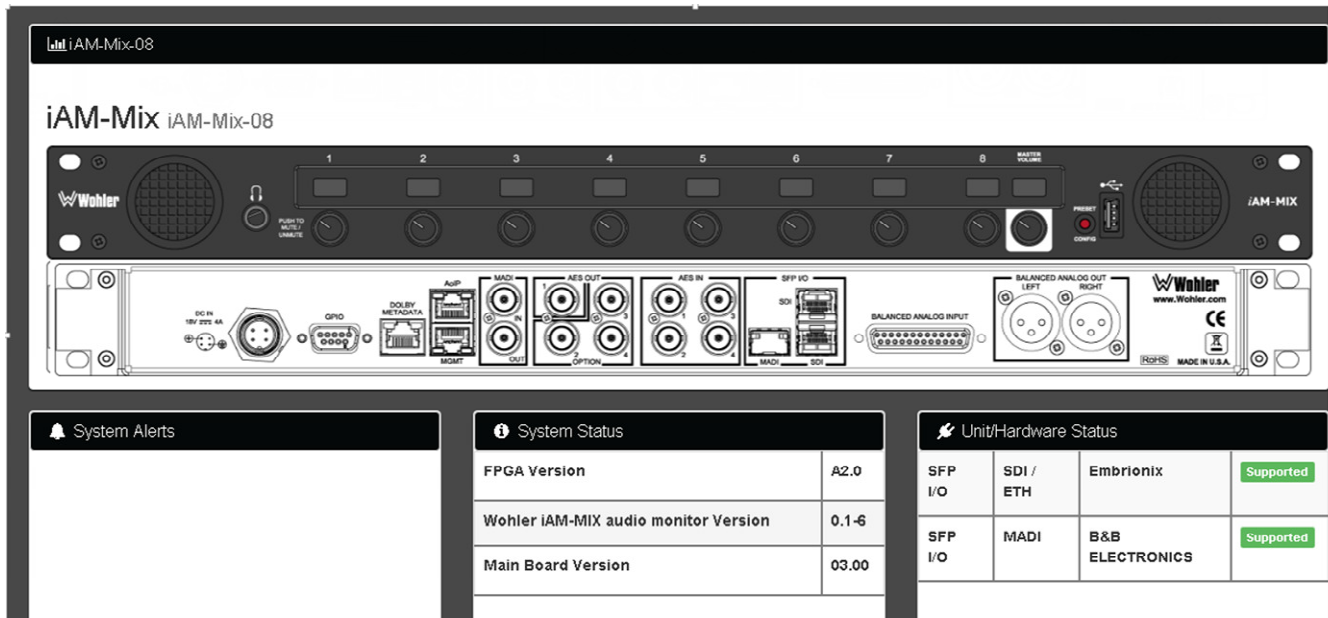

Sign In

Only authorized users should be allowed to make Preset and network changes. Anybody can view the status of iAM-MIX units on the network, but logging in with a password is required to make any changes. When logging in is required to make a change, the page shown in Figure 4-4 will appear. Alternatively, login can be done at any time by clicking on **Administrative Account** selection in the upper right portion of the browser page and clicking **Log In**.

Figure 4–4: Administrative Account Log In

Administrator Account Selection

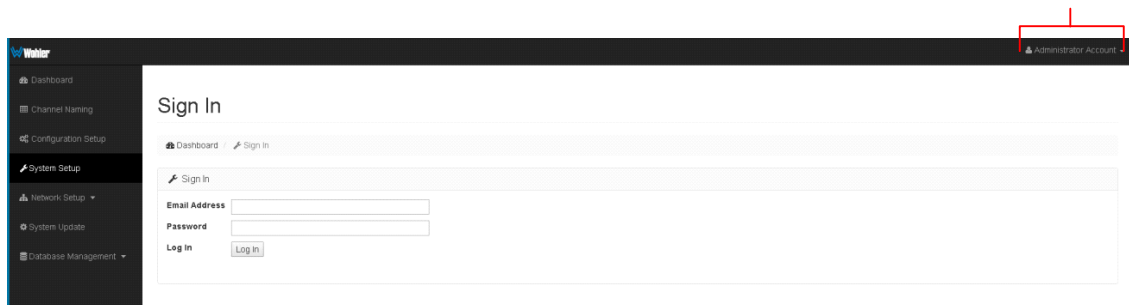

By default, the **Email Address** is 'admin@admin.com'.

By default, the **Password** is 'admin'.

You can change the password of the administrative account on a unit by unit

basis to suit your security needs. You will remain logged in until the browser window is closed or the session is disconnected physically or virtually, or **Log Out** by clicking **Administrator Account** in the upper right of any page.

Channel Naming

Each channel can be assigned a name in the configuration database. There is a separate set of names for each input type, selected by the upper row check boxes. The default names (labels) can be changed by normal cursor text entry operations in your browser and device.

These names will be automatically assigned to the channel-strip label fields in a Preset when selected. Channel names will appear on remote metering screens, but not on front panel screens, due to space limitations.

Figure 4–5: Channel Naming

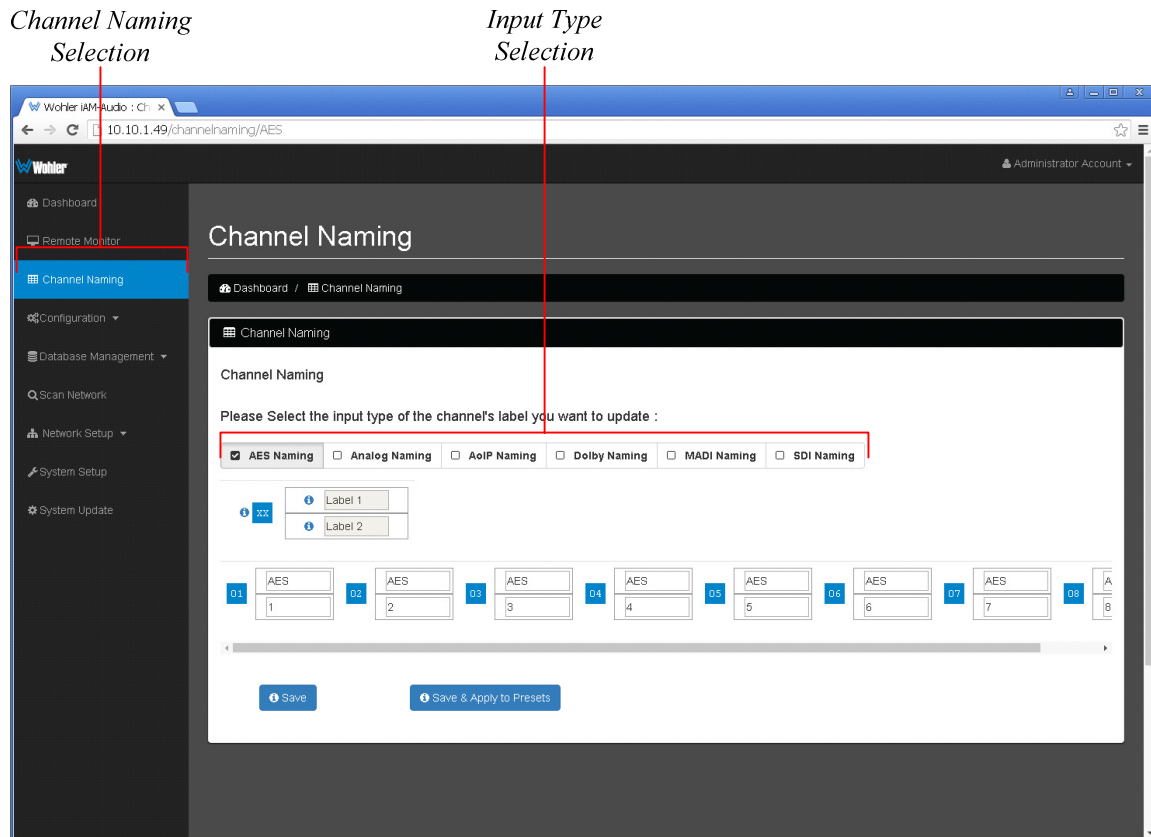

Configuration - Setup

Factory default Presets are provided for each input type and the first eight or sixteen channels in consecutive order. Default mixes are left for odd-numbered channels and right for even-numbered channels. If one of those simple arrangements works for your application, there is no need to change any of your Presets, since the monitor can be left set to that Preset.

The Configuration page is where the setup can be made in virtually any arrangement. Clicking through from the Dashboard screen will present that Preset for configuration. Select other Presets for editing by clicking on the **Recall Configuration** box.

Figure 4–6: Configuration

*Configuration –
Setup
Selection*

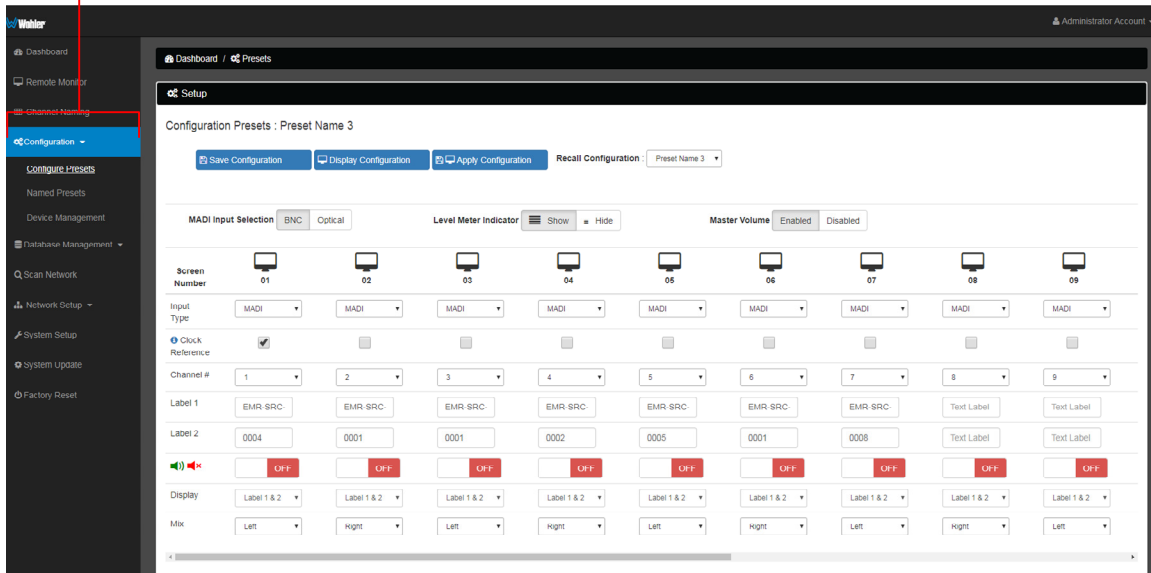

There are several settings available for each channel:

1. If **BNC** and **Optical** sources are installed, the **MADI Input Selection** switch will appear. Only one can be enabled for each Preset, though different Presets can use either one.
2. **Level Meter Indicator** will **Show** or **Hide** activity meters on front panel displays.
3. **Master Volume** will allow you to **Enable** or **Disable** the right-hand front panel encoder to either adjust the overall volume or to adjust the volume of channel 16. This selection is only available on 16-channel units and does not appear on 8-channel units, because 8-channel units have a dedicated Master Volume control.

4. The **Input Type** box switches between the available inputs. Inputs are enabled by software licenses and the optical input must have an SFP module installed for it to work. The iAM-MIX loops the selected incoming MADI stream to both coax and fiber outputs (if installed).
5. Check the **Clock Reference** box for the input to serve as clock sync reference. An SDI or MADI stream may exhibit some audible clicks if it is not synchronized externally and is not selected as the clock reference. **A missing signal selected as the clock reference can prevent all audio from being monitored. It can also prevent the iAM-MIX integration with external routers from working.**
6. **Channel#** is where the source channel for each strip location is set.
7. The **Speaker ON / OFF** switch allows channels to be set as active or muted when the Preset is changed. After that, mute/unmute is controlled by the front panel operator.
8. **Label 1** shows what will be displayed on the upper line of the channel strip, like a scribble strip on a mixing board. **Label 2** is for the lower line displayed. Both labels will be automatically retrieved from the **Channel Naming** page when first selected here. Those names can be changed for this Preset, without affecting the Channel Naming labels.
9. The **Display** box provides a way to not use one of the labels, for instance, if the labels have too many characters for both labels to fit in the display.
10. **Mix** is where you can set Left, Right or Left & Right mix assignments for the input source audio to be heard on front panel speakers and headphones, and how the rear panel outputs are mixed.
11. **Save Configuration** stores the Preset in the database. Saved Preset Configurations can be copied onto a USB flash drive, which can be inserted into the front panel USB jack on iAM-MIX units to quickly duplicate configurations on multiple units.
12. **Display Configuration** loads the current (edited) Preset into the iAM-MIX for test purposes only. It will not be stored, and cannot be recalled later.
13. **Apply Configuration** saves the Preset to the database and loads it as the active Preset.

Configuration – Named Presets

Change Preset names on this page. Click **Save** to store the new name(s).

Figure 4–7: Save Preset

*Configuration -
Named Presets -
Selection*

The screenshot shows the 'Configuration' page in the Wohler interface. The sidebar on the left contains navigation items: Dashboard, Remote Monitor, Channel Naming, Configuration (selected), Configure Presets, Named Presets (highlighted), Database Management, Scan Network, Network Setup, System Setup, and System Update. The main content area is titled 'Configuration' and shows a breadcrumb 'Dashboard / Preset Management'. Below this is a section for 'Presets Management' with the instruction 'Please update a preset name from list below.' A table lists 8 presets with their names in input fields and checkboxes for 'Last Applied Configuration'. The second preset, 'Mike's SDI 1-16', has its checkbox checked. A 'Save' button is located at the bottom left of the table.

	Name	Last Applied Configuration
1	<input type="text" value="Jerry's AES/Analog"/>	<input type="checkbox"/>
2	<input type="text" value="Mike's SDI 1-16"/>	<input checked="" type="checkbox"/>
3	<input type="text" value="MADI BNC 1-16"/>	<input type="checkbox"/>
4	<input type="text" value="MADI BNC 17-32"/>	<input type="checkbox"/>
5	<input type="text" value="MADI BNC 33-48"/>	<input type="checkbox"/>
6	<input type="text" value="MADI BNC 49-64"/>	<input type="checkbox"/>
7	<input type="text" value="Preset Name 7"/>	<input type="checkbox"/>
8	<input type="text" value="Preset Name 8"/>	<input type="checkbox"/>

Configuration – Device Management

This page is used to manage integration with Grass Valley systems to automatically set the text in the labels on the channel strips. Grass Valley integration can be used for AES and SDI audio monitoring interfaces.

Evertz and Tally integrations do not require any setup. They are used for the MADI audio monitoring interface.

Figure 4–8: Device Management

*Configuration –
Device
Management*

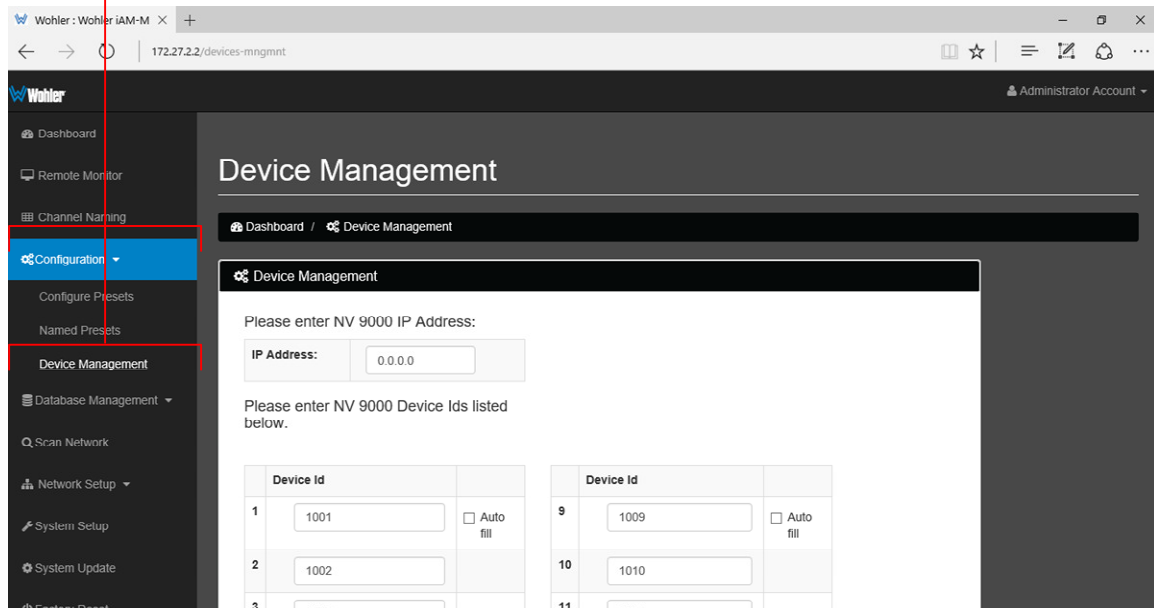

To set up Grass Valley integration, use the following steps:

1. Enter the network address of the Grass Valley NV9000 router control system in the **IP Address** box as shown in Figure 4-8.
2. Enter channel number to be routed in **Device ID** field.
3. Check the **Auto fill** box. This will fill all of the other **Device ID** fields automatically and incrementally.
4. Click the **Apply** button at the bottom of the page.
5. Check that the required **Clock Reference** is checked on the **Configuration - Setup** page. If there is no clock reference, the integration cannot work.

System Setup

The **System Setup** page expands upon the status information available in the Dashboard page, showing the installed option licenses, and provides a means to add additional option licenses.

Figure 4–9: System Setup

*System Setup
Selection*

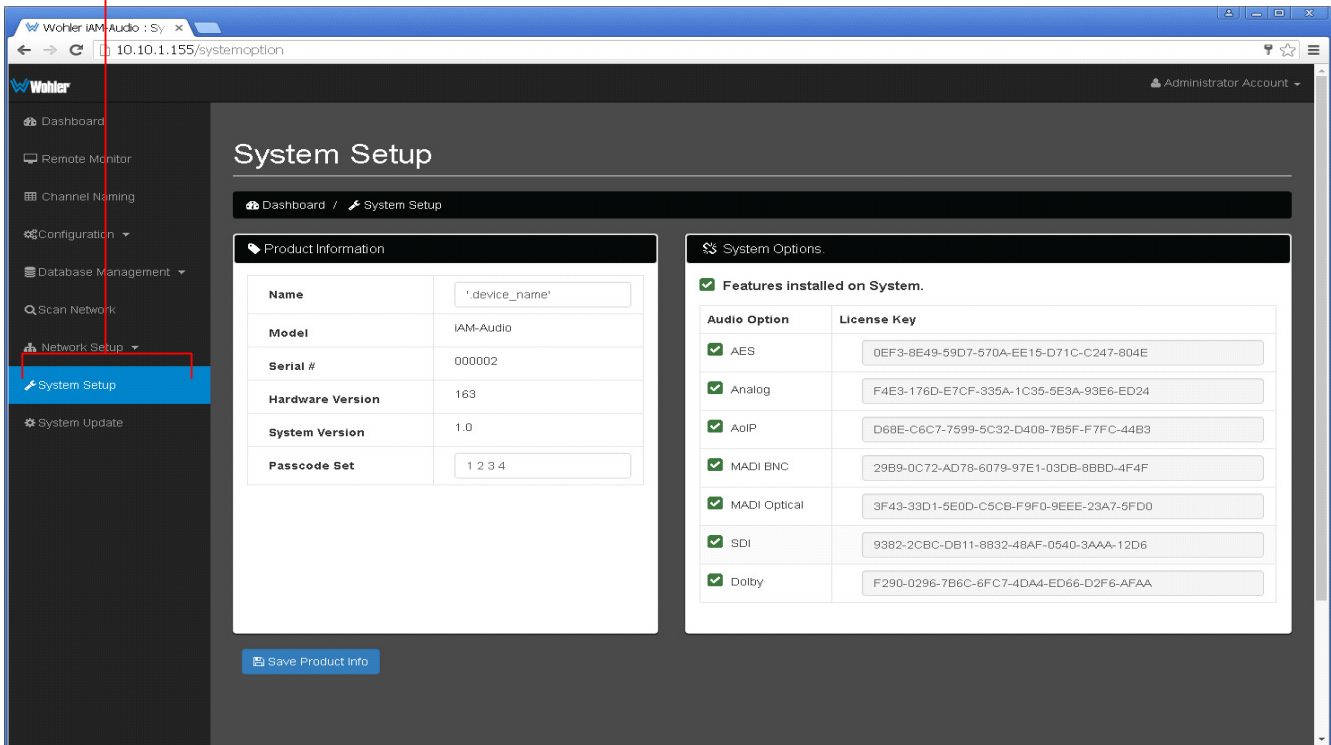

The example above shows an iAM-MIX-8 with several sources installed and the license keys displayed for reference. Licenses without keys will not have the box checked. Click on an unchecked box to allow entry of the license key provided by Wöhler Customer Service. Once entered, saved and accepted, the new license is available for use.

Scan Network-Discovery

This page will scan the network for Wohler iAM monitors installed on the network. Other devices can have their network settings reconfigured by clicking the Edit (pencil) icon. Information about the **Updates** tab is in [Installing Software on Networked iAM-MIXs](#).

Figure 4–10: Active Device Discovery

Scan Network Selection *Discovery Selection*

Name	MAC	Serial#	Model	FW ver.	IP Addr	IP Mask	IP GW	Type
'device_name'	80:30:dc:97:d9:1f	000002	IAM_AUDIO		<input type="checkbox"/> 10.10.1.155	255.255.255.0	10.10.1.1	Static
-101017	54:4a:16:bb:89:24	101017			<input type="checkbox"/> 10.10.1.70	255.255.255.0	10.10.1.1	Static
iAM-Audio	54:4a:16:bb:33:47	101013	IAM_AUDIO		<input type="checkbox"/> 10.10.1.250	255.255.255.0	10.10.1.1	Static

Click on another MAC to Select

Network Setup

Make network **IP Address** changes for the local iAM-MIX unit's **Management (MGMT) Port** here.

Figure 4–11: Set IP Addresses

*Network Setup –
Set IP Addresses
Selection*

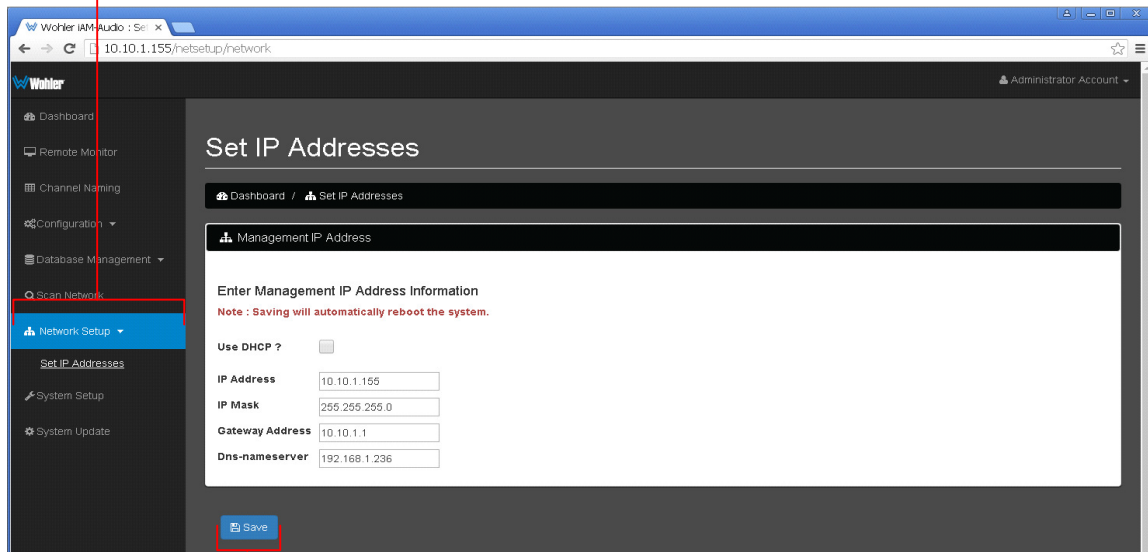

Click to Save new address and reboot iAM-AUDIO

The procedure for changing the IP Address information is as follows:

1. **Use DHCP?** Check this box if your network has a DHCP server and you want to use dynamic addressing. Otherwise, you must enter static IP address entries in the four fields which follow.
2. **IP Address:** Enter the network address. Leading zeroes are not required.
3. **IP Mask:** This should usually be 255.255.255.0 unless your network can work across multiple subnets.
4. **Gateway Address:** This should usually be the same domain and subnet address numbers as the IP Address, but with the last octet being .1.
5. **DNS-nameserver:** A default value is shown for reference only. DNS is not normally required for basic static IP network configurations to work. Your IT administrator will specify a value to work with mixed static/dynamic network setups.
6. **Save:** When you have made all of the necessary entries, press **Save** to apply the changes internally before rebooting the unit.

Database Management

Export Configuration

Use this page to offload an iAM-MIX Preset database to a USB flash drive, inserted in the front panel port. Follow the instructions on the bottom of the page to complete the procedure.

Figure 4–12: Database Export

*Database Management –
Import / Export Presets
Selection*

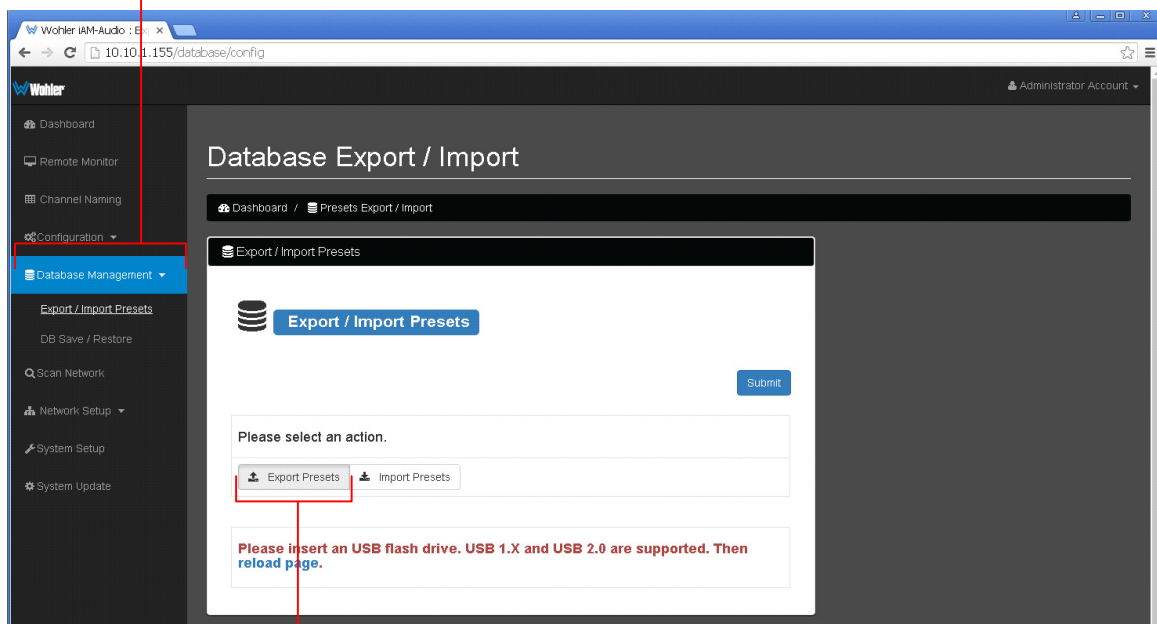

Click to Export Presets

Use the following steps:

1. Click the **Export Presets** button on the **Database Management - Database Export / Import** page.
2. Insert a flash drive in the front panel USB jack on the iAM-MIX you want to back up.
3. Click the blue **reload page** link at the bottom of the page. The Preset data will be written onto the Flash Drive. Do not withdraw the Flash Drive before all of the data is written to it.

These instructions are summarized on the **Database Management - Database Export / Import** page.

Import Configuration

Use this page to retrieve Presets from a USB flash drive inserted in the front panel port. Follow the instructions on the bottom of the page to complete the procedure.

Figure 4–13: Database Import

*Database Management –
Import / Export Presets
Selection*

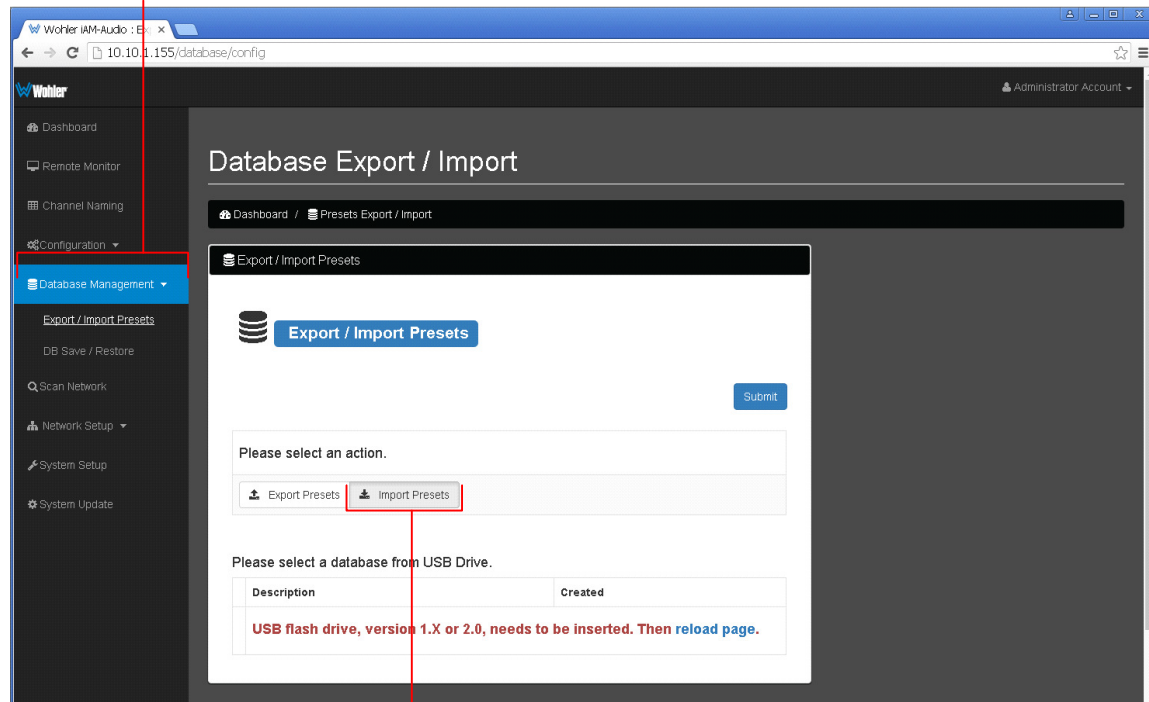

Click to Import Presets

Use the following steps:

1. Click the **Import Presets** button on the **Database Management - Database Export / Import** page.
2. Insert a flash drive in the front panel USB jack on the iAM-MIX you want to recover Preset data from.
3. Click the blue **reload page** link at the bottom of the page. The list of Preset databases that are contained on the Flash Drive will appear on the screen.
4. Select a Preset database from the list. The Preset data you selected will be copied into the iAM-MIX. Do not withdraw the Flash Drive before all of the data is copied.

These instructions are summarized on the **Database Management - Database Export / Import** page.

Save / Restore Database (DB)

This page is used to make a backup copy of the database within an iAM-MIX unit from which a Restore Database operation can be performed. The dataset stores various information about the unit, including the existing network configuration, channel names, presets, product information and other information.

Refer to the list of databases at page bottom. There will only be one database until a new one is **Saved**.

The backup is made to the unit itself, not to a separate USB or network file. Multiple database copies may be created until a limit is reached, at which point existing copies must be deleted before a new one can be created.

Figure 4–14: Save / Restore Database

*Database Management –
Save / Restore DB
Selection*

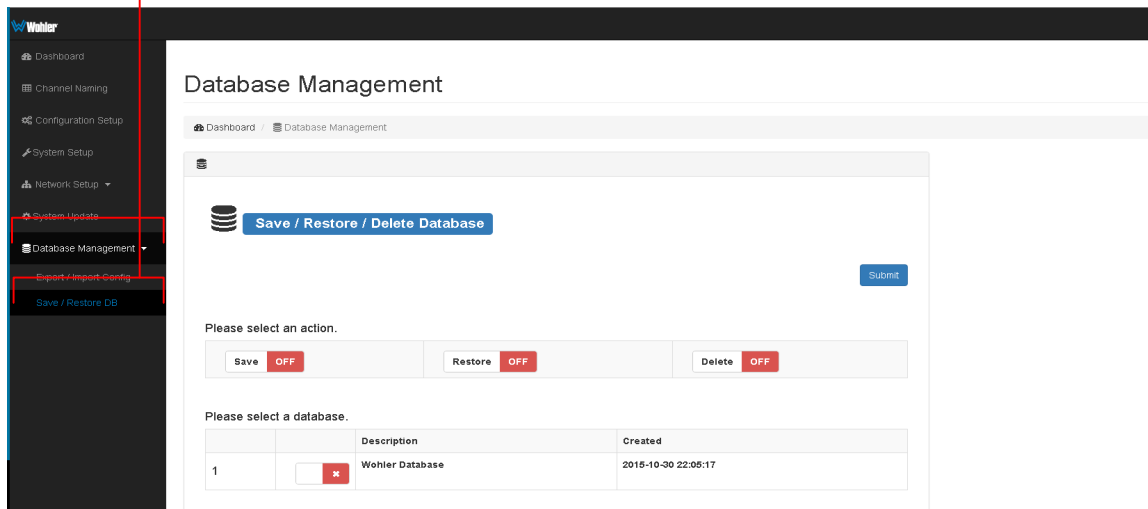

An automated database copy will be created whenever you import presets from a new unit in order to enable recovery from a failure.

Use **Save** when you have made modifications to the Database and want to preserve a backup copy of it.

Use **Restore** to reverse database corruption if you notice or suspect the Presets are not appearing correctly.

There is no need to **Delete** a database until the maximum number has been reached, to make room for a new one.

Factory Reset

It can be useful to bring all of the settings of the iAM-MIX back to the way they were when it left the Wohler factory if the iAM-MIX is being reinstalled at a new location. This page is used to reset all of the settings in the iAM-MIX to their original.

Figure 4–16: Factory Reset

Factory Reset Selection

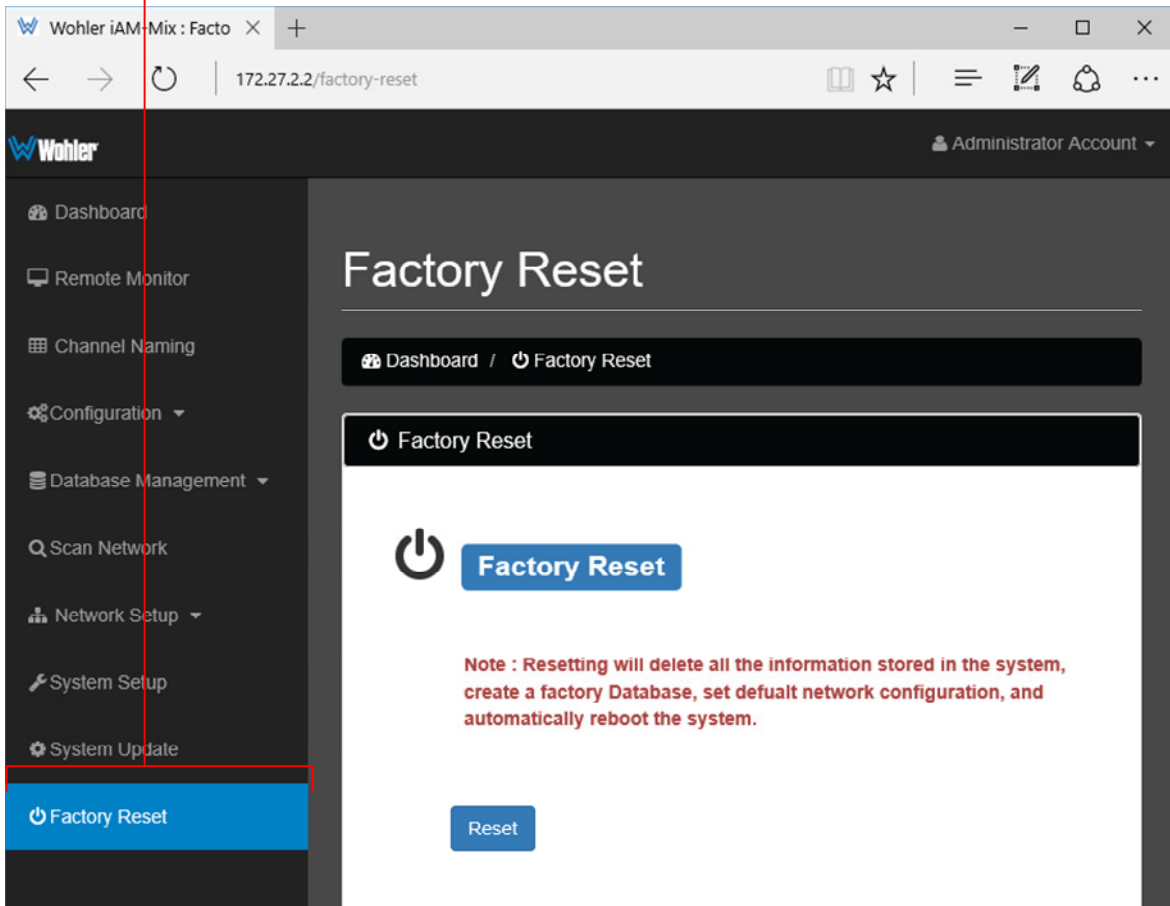

APPENDIX A: Software Upgrades

Introduction

This chapter describes how to download a software update file to your computer, transfer it to a USB flash drive and install the update into an iAM-MIX.

Download the Software

The iAM-MIX software update can be found at <http://www.wohler.com>, under Product Downloads on the Products > iAM-MIX page, in Support > Downloads > Drivers & Software, or contact Wohler Customer Support for more information.

Unzip and copy the update file(s) from your computer to the root directory (not inside a folder) of a USB flash drive. It must be FAT32 file type, and does not need to be empty.

Both local and network update methods require that a USB flash drive, with Wohler Update Package(s) installed on it, be inserted into the front panel USB jack.

Important:

The iAM-MIX Web GUI is required to perform the software upgrade procedure. Refer to Chapter 4 **First Time IP Assignments** if not already set up for your network.

Installing the Software Locally

Click on the **System Update** selection in the iAM-MIX Web GUI.

System Information in the right pane shows currently installed software and hardware versions.

Figure A–1: System Update

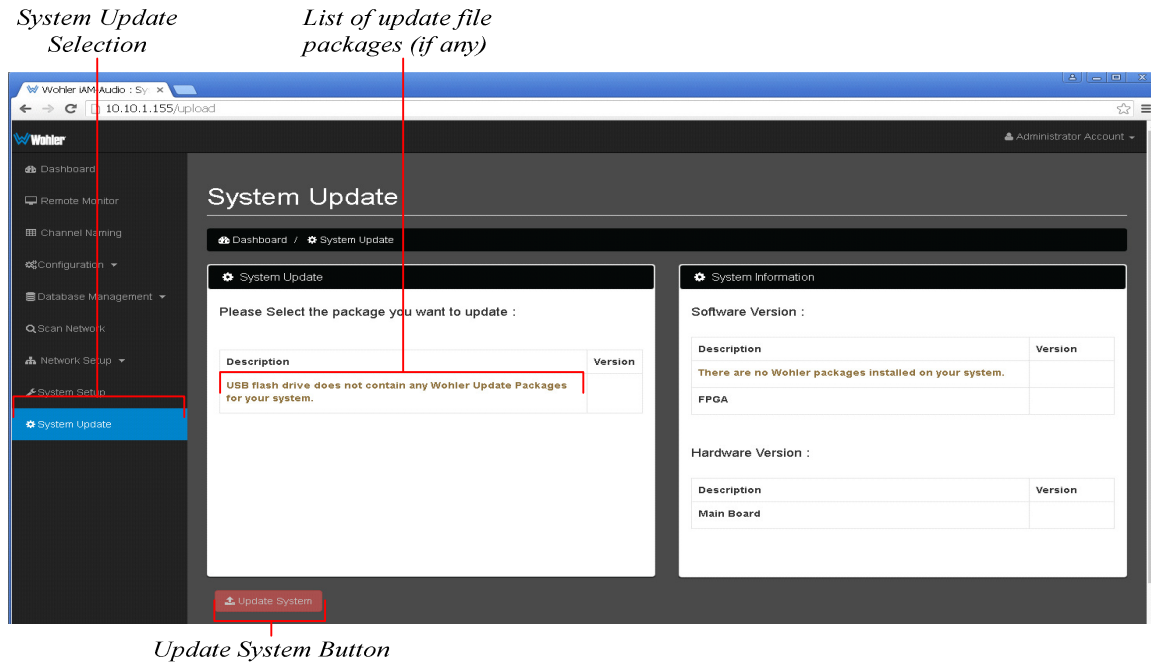

Use the following steps to install a new software package into the iAM-MIX:

1. Insert the USB flash drive with iAM-MIX update package(s) into the front panel USB jack. Refer to the [Download the Software](#) section of this chapter for the specifics of download and file transfer to the USB flash drive.
2. A list of update file packages present on the USB drive will appear in the **Description** field area shown in Figure A-1, along with software **Version** number(s). Click on the one you want to use. If the “**USB flash drive does not contain ...**” message below appears, the system has the latest software in it, and no further action is required or possible.
3. Click **Update System** button.

Important:

Do not interrupt or remove power to the iAM-MIX, or remove the USB drive during the installation process. Doing so could crash the iAM-MIX software.

4. The iAM-MIX Web GUI will indicate progress of the software installation and results.
5. The iAM-MIX will display a message when the upgrade is complete and then reboot.
6. Remove the USB drive any time after upgrade is complete.
7. After the iAM-MIX reboots, **Refresh** the browser by either clicking on the Wohler logo or closing and reopening the browser, for normal operation of the iAM-MIX Web GUI.

Installing Software on Networked iAM-MIXs

This page will scan the network for Wohler iAM monitors installed on the network and allow firmware updates of compatible and accessible iAM-MIX units.

An iAM must be of the same type. For example, an iAM-MIX cannot be updated by an iAM-AUDIO update. An iAM-MIX must be on the same IP subnet to be updated.

Figure A–2: Active Device Discovery

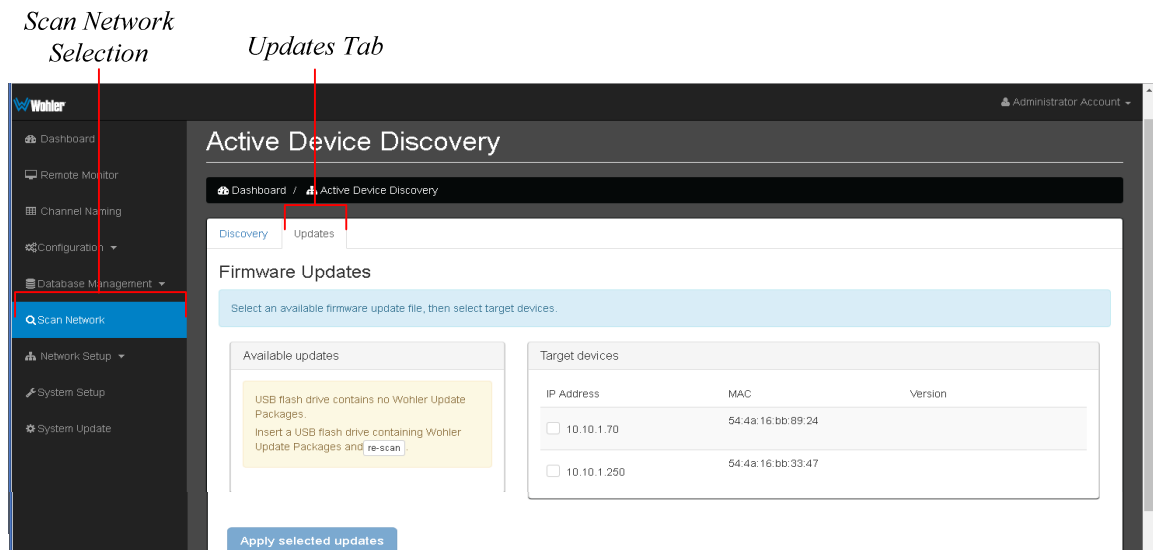

Use the following steps:

1. Refer to the [Download the Software](#) section of this chapter for the specifics of download and file transfer to the USB flash drive.
2. Insert the USB flash drive with iAM-MIX update package(s) into the front panel USB jack of the networked iAM-MIX that you wish to update.
3. Click the **Scan Network** selection.
4. Select the iAM-MIX to be updated from the list shown. Refer to the

- Scan Network - Discovery** section of Chapter 4 and to Figure 4-9.
5. Click the **Updates** tab.
 6. Follow the instructions that appear on the screen. **Do not remove power to the iAM-MIX, or remove the USB drive during the installation process.**
 7. The update is complete when the iAM-MIX restarts and returns to normal operation.

APPENDIX B: Dante Network Setup

Introduction

Installing the iAM-MIX into an existing and functioning Dante network is virtually plug and play. The iAM-MIX rear panel AoIP jack supports 1Gb/s and 100Mb/s Ethernet devices in Dante Audio over IP network configurations.

iAM-MIX channel source selections are made by choosing **Input Type 'AoIP'** in the [Configuration-Configure Presets](#) page regardless of which AoIP option is installed.

The iAM-MIX is set up at the Wohler factory to be used as a slave rather than a master within the Dante network. Other devices or software, such as a **Dante Controller**, are expected to be responsible for most device configurations and all audio routing.

Figure B–1: Network View

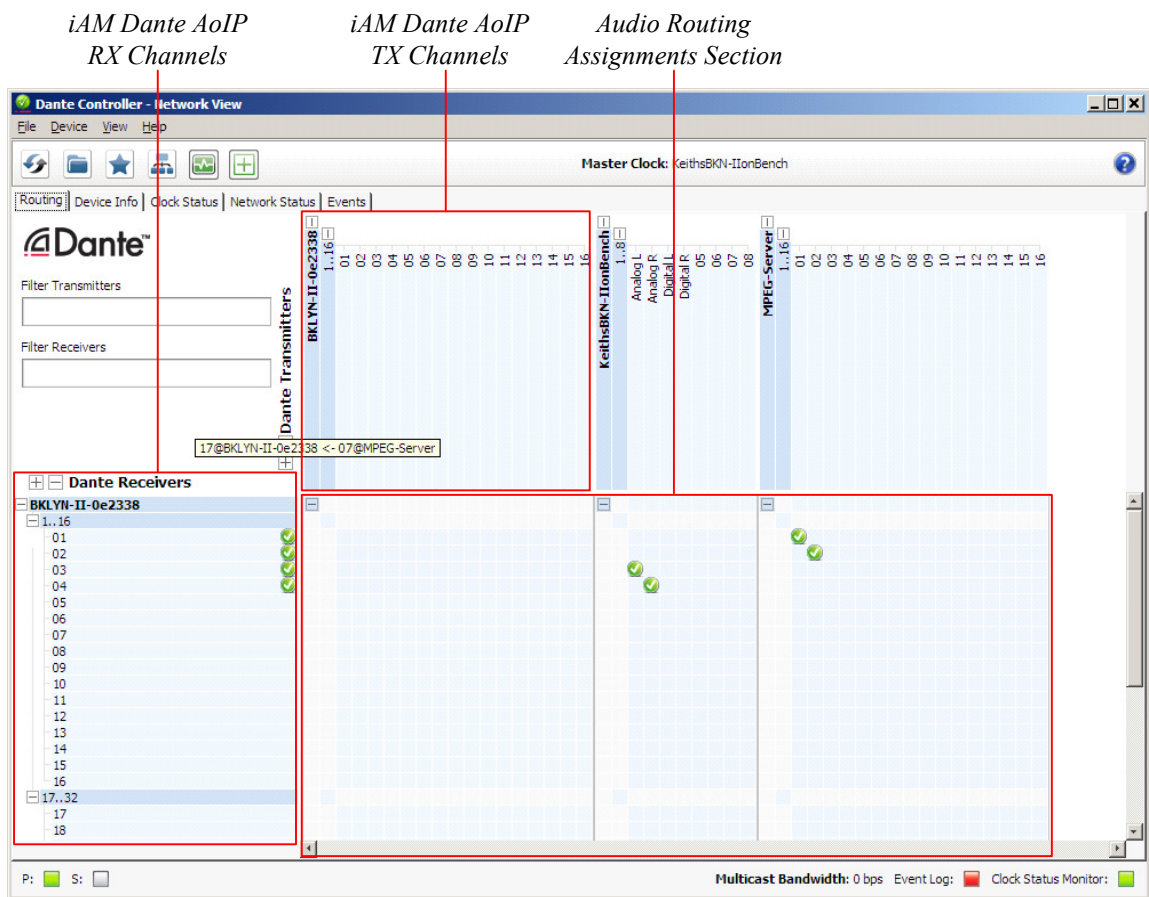

Please refer to the **Dante Controller User Guide** or other control device

documentation for specific network and device setup information.

What is in the iAM-MIX for Dante

The Audinate Brooklyn II board automatically recognizes Dante networks when installed, will alert other devices of its presence and configuration, and will configure its AoIP address per DHCP or local link protocols. There is no need to set a static address for the iAM-MIX Dante port, so no address entry method is provided in the iAM-MIX for Dante network setup. While it is possible to **Manually Configure an IP Address** from the network, this is *not* a recommended Dante practice and should not be done.

Figure B–2: Device View

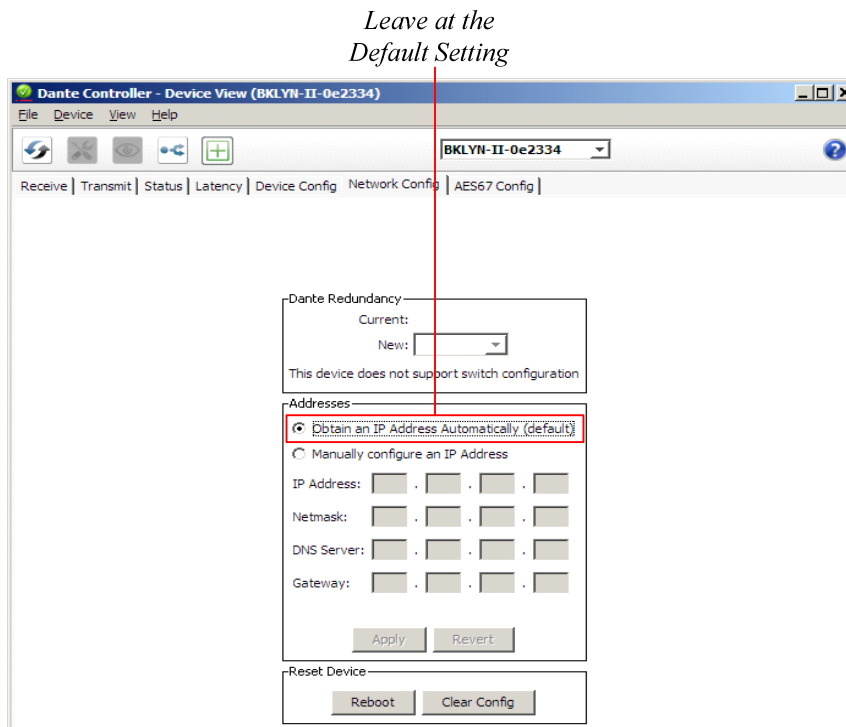

Up to sixteen of the 64 AoIP receive channels can be monitored at once in the iAM-MIX. The sixteen iAM-MIX input channels selected by Presets are transmitted to the Dante network.

The iAM-MIX Dante AoIP is configured by the iAM-MIX to receive up to 64 channels and transmit 16 channels of Dante AoIP at 48 kHz or 44.1 kHz audio sample rates. 48 kHz is the iAM-MIX default rate.

Sample rate selection is left up to the Dante Controller device or software. *All devices connected to each other through a Dante network must be set to the same sample rate.* Slight ticking may be heard in the iAM-MIX monitor when monitoring different input types at different sample rates or if the sources are asynchronous.

Dante Device Setup

The iAM-MIX's default **Dante Device Name** is "BKLYN-II- ..." followed by the last 6 digits of the Dante port MAC address, as shown in Figure B-3. This name can be changed by the Dante Controller to appear that way on the network, but that will not change the iAM-MIX unit name appearing on GUI pages and iAM-MIX remote metering or discovery pages.

Figure B–3: iAM-MIX Name

Dante Device Name

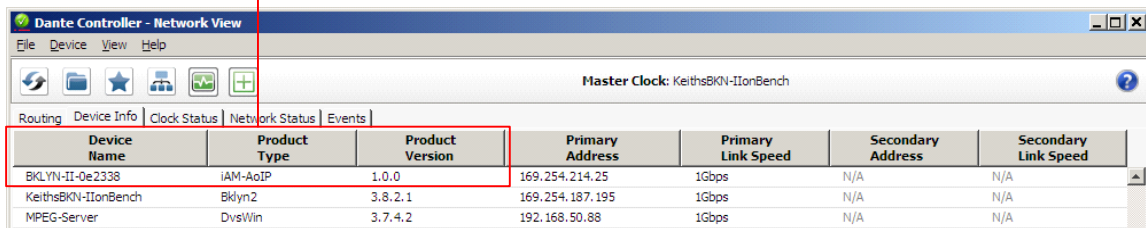

The screenshot shows the Dante Controller Network View interface. At the top, the title bar reads "Dante Controller - Network View". Below the title bar is a menu bar with "File", "Device", "View", and "Help". A toolbar contains several icons. The main area displays "Master Clock: KeithsBKN-IIonBench". Below this is a navigation bar with "Routing", "Device Info", "Clock Status", "Network Status", and "Events". The main content is a table with the following columns: "Device Name", "Product Type", "Product Version", "Primary Address", "Primary Link Speed", "Secondary Address", and "Secondary Link Speed". The first row, "BKLYN-II-0e2338", is highlighted with a red box.

Device Name	Product Type	Product Version	Primary Address	Primary Link Speed	Secondary Address	Secondary Link Speed
BKLYN-II-0e2338	iAM-AoIP	1.0.0	169.254.214.25	1Gbps	N/A	N/A
KeithsBKN-IIonBench	Bklyn2	3.8.2.1	169.254.187.195	1Gbps	N/A	N/A
MPEG-Server	DvsWin	3.7.4.2	192.168.50.88	1Gbps	N/A	N/A

Initial setup operators may want to manually change the iAM-MIX unit Name in the [System Setup](#) page to match the reassigned Dante Device Name for consistency. Refer to Figure B-4.

Figure B-4: Rename iAM-MIX

Change the iAM AoIP Name

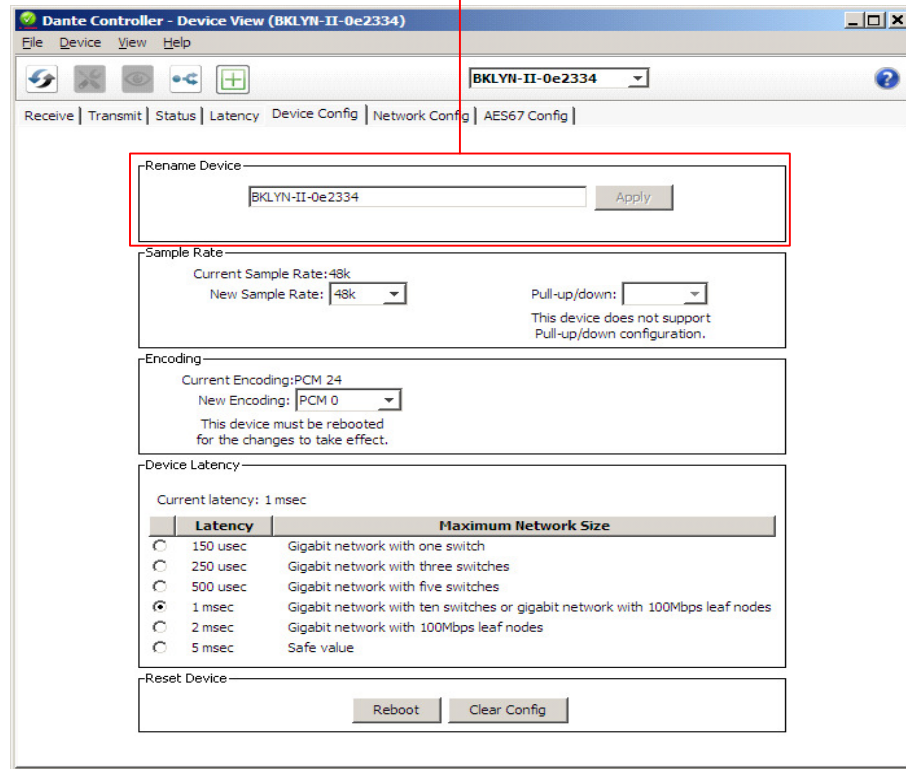

Other changes such as **Latency** settings can be made by the Dante Controller through the **Device View** menus. Some changes may require remote rebooting of the Brooklyn II card to take effect, temporarily interrupting audio and publishing the new information to the network.

Important:

Only 44.1 kHz and 48 kHz audio sample rates are currently supported by the iAM-MIX. The Brooklyn II card would accept a Dante Controller command to operate at other rates, without giving an indication it will not be implemented.

Dante Clock Selection

While the Brooklyn's internal clock is highly accurate, the iAM-MIX does not have provisions for external sync clocks, such as those that are GPS or media reference (video genlock or audio word clock) based. So it is generally not the best candidate to be the PTP Master Clock (commonly called the "grandfather clock") for the network. It can be set as the preferred master if no better clock source exists. Refer to Figure B-5.

The iAM-MIX Brooklyn Dante card will serve as a temporary fallback clock source if preferred masters are interrupted. It functions as an accurate slave clock synchronized to the master clock on the network when not operating

as the master.

Figure B–5: Clock Selection

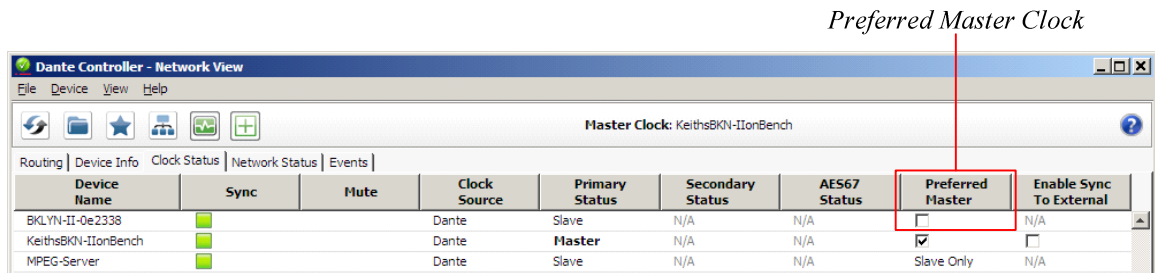

Channel Names

The iAM-MIX uses the BKLYN-II default network channel names of Tx 01-16 and Rx 01-64. The network controller can change these names as desired, but iAM-MIX channel selections will remain as the original default numbers, unless changed in the [Channel Naming - AoIP](#) page. Note these iAM-MIX internal channel names are not passed to the Dante network for discovery purposes, and are internal to the iAM-MIX.

It is recommended for best operator understanding and system administrator reference that channel name changes made over the Dante network be manually entered in the iAM-MIX **Channel Naming - AoIP** page to match.

AES67

The iAM-MIX Brooklyn II can be configured for AES67 operation. AES67 operation with Dante is limited to eight or less receive and transmit channels at 48 kHz sample rates.

24 bit linear (L24) encoding and 1 msec packet time are fixed default transmit parameters.

16 bit (L16) or 24 bit (L24) encoding and 125/250/333/100 µsec packet times can be received.

The **Device View - AES67 Config** menu enables/disables AES67.

Figure B–6: AES67 Enable/Disable

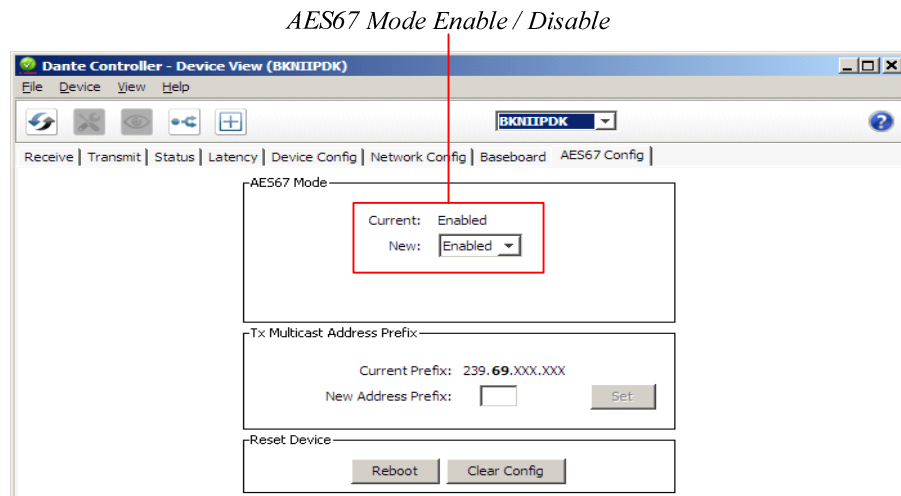

Further, Dante AES67 discovery and operational protocol requires manual assignments for static multicast transmit and receive IP addresses per Dante protocols for discovery and IGMP network operation. Destination addresses in range 239.nnn.0.0 – 239.nnn.255.255, port 5004 or nnn can be configured using the Dante Controller. The default is 69. The destination and receive address range must match. Provisions for this are in **Dante Controller Device View - Network Config**. Refer to Figure B-7.

Figure B–7: Device View - Network Config

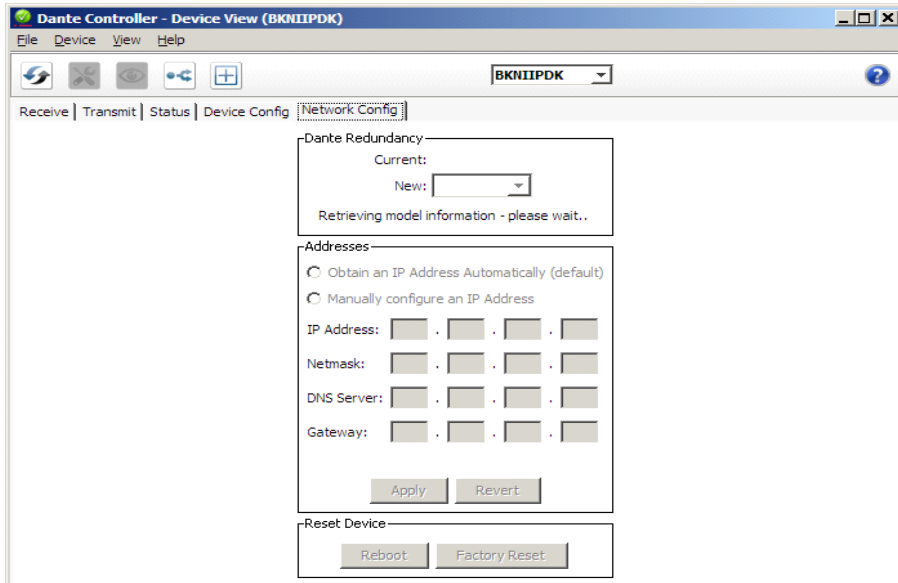

The channels to be multicast are selected in the File menu-**Create Multicast Flows** window shown in Figure B-8.

Figure B–8: Multicast

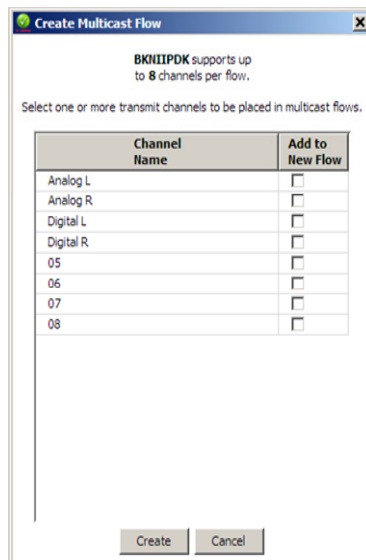

Device Lock

Audinate recently added a feature whereby a remote controller can send a command to lock Dante network devices' configurations. The iAM-MIX does not implement the Device Lock command at this time.

Dante Firmware Upgrades

Wohler iAM-MIX monitors ship with current Brooklyn II firmware as of the option installation date. The version information is found in the **Dante Controller Device View-Status** page. iAM-MIX software/firmware is tested with the latest Dante code release. Therefore it is strongly recommended that iAM-MIX and Dante software/ firmware be updated at the same time to ensure compatibility and support of the latest features.

Use the Audinate **Dante Firmware Update Manager** Windows or OS X application to update the Dante firmware over the Dante network. Follow the application's installation and usage guide plus any applicable technical notes available.

Follow instructions in [Software Upgrades](#) for iAM-MIX updates.

APPENDIX C: Ravenna Network Setup

Introduction

Installing the iAM-AUDIO into an existing and functioning Ravenna network is virtually plug and play. The iAM rear panel AoIP jack supports 1Gb/s and 100Mb/s Ethernet devices in Ravenna Audio over IP network configurations.

iAM-AUDIO channel source selections are made by choosing **Input Type 'AoIP'** in the [Configuration-Configure Presets](#) page regardless of which AoIP option is installed.

What is in the iAM-AUDIO for Ravenna

The AES67 enabled Coveloz Bach board supports the following features:

RAVENNA-compatible talker/listener:

- 1) RFC 3551 – RTP Profile for Audio and Video Conferences
 - a) L16 16-bit linear format defined in RFC 3551 clause 4.5.11
 - b) L24 24-bit linear format defined in RFC 3190 clause 4
 - c) AM824 24-bit Audio as defined in IEC61883-6
 - d) Multicast and unicast session support
 - e) 48 kHz and 96 kHz audio sampling rates
 - f) 1 to 8 audio channels per stream
 - g) Up to 256 streams
- 2) Media clock support
 - a) 48 kHz and 96 kHz
- 3) Hitless Stream Redundancy
- 4) IGMP v3 support
- 5) Session Announcement Protocol (SAP) support

AVB Ethernet features:

AVB uses the concept of streams and channels. A stream is a connection from one talker to one or more listeners. One stream can be made up of 1-60 audio channels. The Ravenna option supports the following AVB features:

- 1) AVB 1722 AVTP with multiple subtypes:
 - a) IEC 61883-6 MBLA
 - b) AM824, 24-bit Audio Encapsulation
 - c) Support up to 64 streams
 - d) Up to 8 channels per stream

- e) 512+512 Channels of audio
- f) 48kHz and 96kHz sampling rates
- 2) IEEE 802.1Q/SRP
- 3) IEEE 1722.1/AVDECC control
- 4) IEEE 802.1AS/gPTP
- 5) Compatible with Apple OS X devices, such as MacBooks and MacMini computers
- 6) Media clock per the AVnu specification
- 7) Hitless stream redundancy

BACH™ Controller Graphical User Interface:

The BACH board includes a Graphical User Interface to review and manage the Bach board. It provides an interface to:

- 1) Manage connections with ease
 - a) Display discovered devices and streams
 - b) Connect streams from network to local destinations
 - c) Start, stop and monitor stream health/status
- 2) Enable local BACH™ device configuration & status reporting. Examples include:
 - a) Receive buffer statistics
 - b) Ethernet statistics
 - c) Alarms

The context is device-specific, meaning that:

- 1) a stream "source" refers to this device's source
- 2) One can change context to another device by selecting it on the Cloud Page

Home Page

You can navigate to different pages within the Bach Controller GUI to review or perform various functions.

The **Home** page can be accessed by entering the 172.27.2.30 IP address. It gives a device overview and stream status.

Figure C–1: BACH Controller Home Page

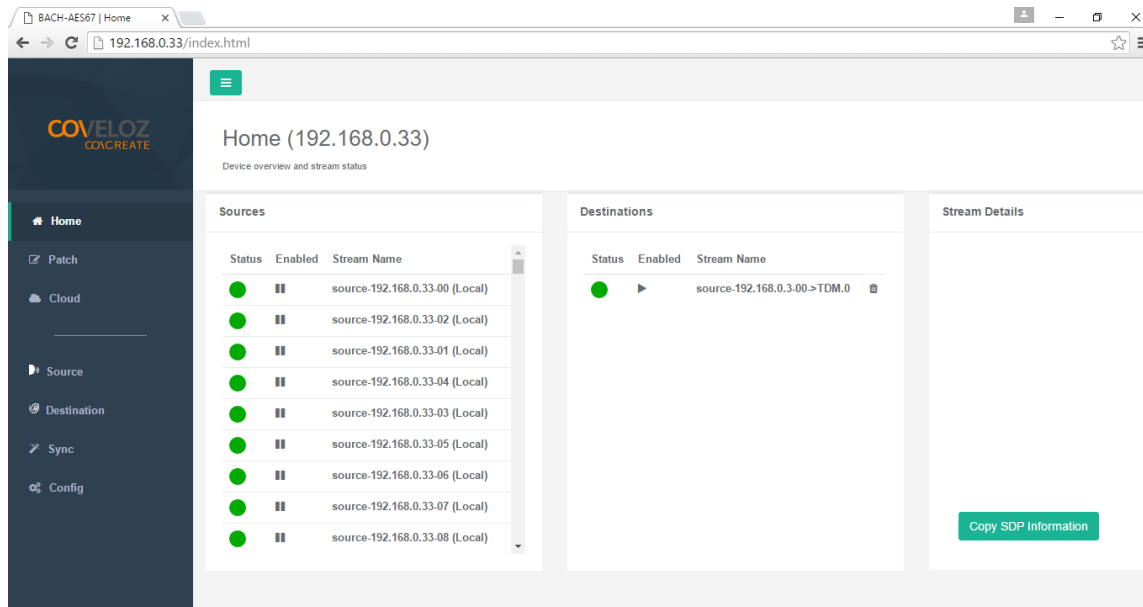

Patch Panel

The **Patch** page enables routing of connections between listener and talker channels for devices on the network. The highlighted green square indicates a routing connection between a source or talker (left) and a destination or listener (bottom). The Web GUI will allow selection of channels to monitor from among the listeners (bottom).

Figure C–2: BACH Controller Patch Panel

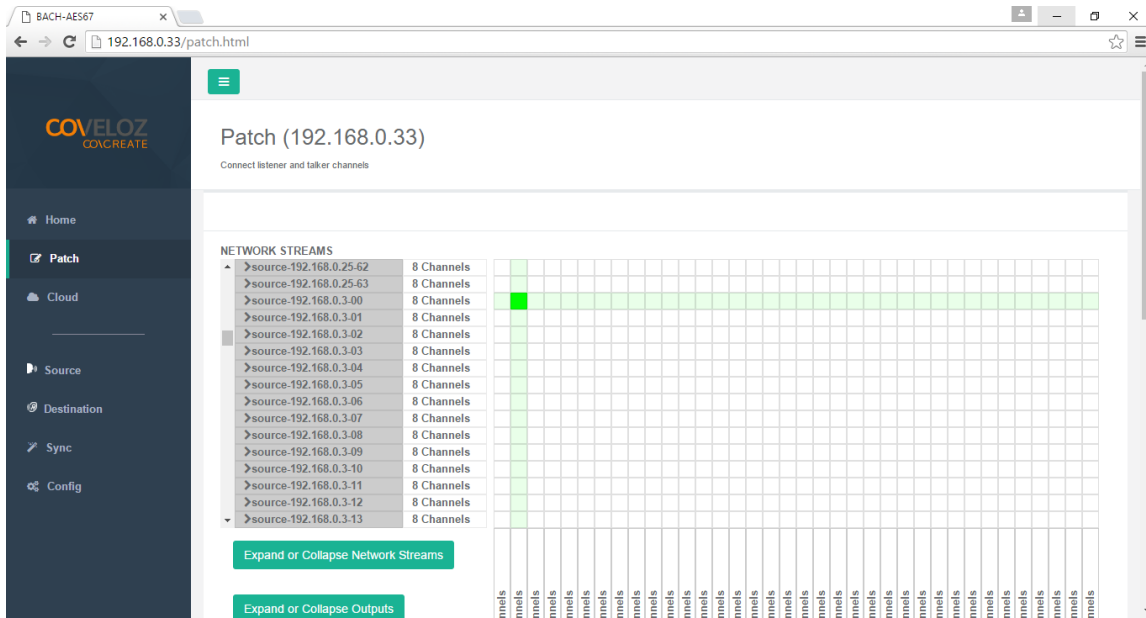

Controller Cloud

The **Cloud** page shows any Ravenna devices on the given network, including any Wohler devices with the Ravenna option installed.

Figure C–3: BACH Controller Cloud Page

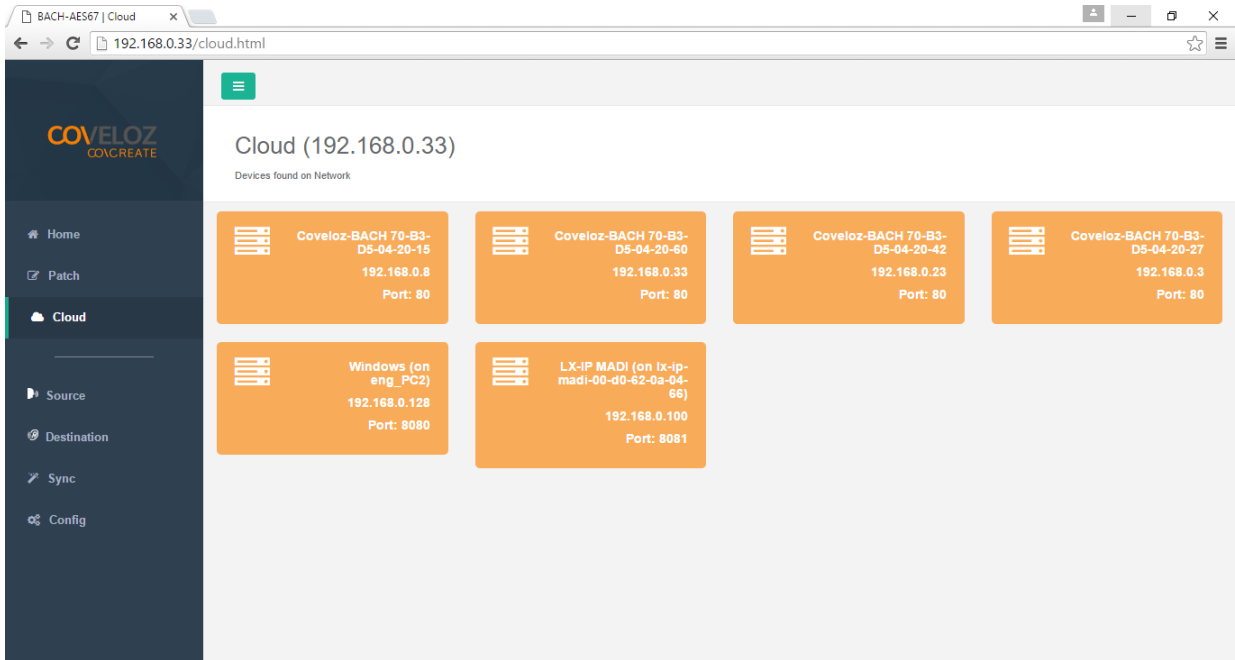

Source Streams

The **Source** provides in-depth information on source streams that are transmitting (sourcing) Ravenna signals from devices on the network.

Figure C–4: BACH Controller Source Stream

The screenshot displays the BACH Controller Source Stream configuration interface. The browser address bar shows the URL `192.168.0.33/talker.html#`. The page title is "Source (192.168.0.33)". Below the title, there is a description: "Source gives you in-depth information on your Source devices." The main content area is divided into two sections: "Sources" and "Advanced".

The "Sources" section contains a table with the following data:

Name	Status	On / Off	#Ch	Audio Format	Delete
source-192.168.0.33-00	●	OFF	8	L24	🗑️
source-192.168.0.33-01	●	OFF	8	L24	🗑️
source-192.168.0.33-02	●	OFF	8	L24	🗑️
source-192.168.0.33-03	●	OFF	8	L24	🗑️
source-192.168.0.33-04	●	OFF	8	L24	🗑️
source-192.168.0.33-05	●	OFF	8	L24	🗑️
source-192.168.0.33-06	●	OFF	8	L24	🗑️
source-192.168.0.33-07	●	OFF	8	L24	🗑️

The "Advanced" section contains the following configuration options:

- Source Name:
- Starting Channel:
- # of Channels:
- Codec:
- Transport IP Address:
- UDP:
- DSCP:
- TTL:

An "Add Source" button is located at the bottom right of the "Sources" table.

Stream Destinations

The **Destination** page provides in-depth information on your destination devices that are receiving Ravenna signals on the network. Clicking the Advanced button provides additional options.

Figure C–5: BACH Controller Stream Destinations

The screenshot displays the 'Destination (192.168.0.33)' page in a web browser. The browser's address bar shows '192.168.0.33/listener.html'. The page features a dark sidebar on the left with the 'COVELOZ COCREATE' logo and navigation links: Home, Patch, Cloud, Source, Destination (highlighted), Sync, and Config. The main content area has a title 'Destination (192.168.0.33)' and a sub-header 'Destinations' with a plus icon. Below this is a table with the following data:

Name	Stream Status	On/Off	#Ch	Audio Format	Link Offset (µs)	Packet Time (µs)	Delete
source-192.168.0.3-00->TDM.0	●	<input checked="" type="checkbox"/>	8	L24	20000	1000	

Sync

The **Sync** page allows you to program parameters relating to Precision Time Protocol (PTP) based time synchronization of network clocks of your BACH-AES67 devices.

Figure C–6: BACH Controller Sync Page

The screenshot displays the BACH Controller Sync page in a web browser. The browser's address bar shows the URL `192.168.0.33/sync.html`. The page title is "Sync (192.168.0.33)" and includes a "Refresh" button. A sidebar on the left contains navigation options: Home, Patch, Cloud, Source, Destination, Sync (highlighted), and Config. The main content area is divided into two sections: "Configuration" and "Status".

Configuration Section:

- Domain:
- Priority1:
-
- ETH port:
- Sync Interval:
- Announce interval:
- Announce Receipt timeout:
-

Status Section:

Grandmaster ID	70-B3-D5-FF-FE-04-20-28
Grandmaster Priority1	127
Offset from master	4971ns
Mean Path delay	3079ns
Clock Accuracy	33ns
ETH port	ETH1
Local ID	70-B3-D5-FF-FE-04-20-61-1
State	Slave
Delay Mechanism	E2E
Sync Interval	0 (1 pkts/s)
Announce interval	1 (0.5 pkts/s)
Announce Receipt timeout	2 pkts

Configuration/Device Management

The **Config** page allows operations such as modifying the IP address, Packet time, Rebooting etc. Configure the Packet Time either as 1ms or 250us.

Figure C–7: BACH Controller Device Management

The screenshot displays the 'Device Configuration (192.168.0.33)' web interface. The left sidebar contains navigation options: Home, Patch, Cloud, Source, Destination, Sync, and Config. The main content area is divided into three sections:

- Settings:** Includes a 'View Device Settings' button, 'Channel Sampling Frequency' (48KHz), 'Packet Time' (1ms), and an 'Update Global' button.
- Configuration management:** Includes buttons for 'Save Running to startup', 'Restore to Default Startup', and 'Reset to Factory Defaults'.
- Firmware:** Includes a 'Reboot Device' button, an 'Update Firmware' button, and firmware details: 'Firmware Version: v0.0.2-30', 'Firmware Date: Fri Sep 30 17:49:22 EDT 2016', and 'Chipid Version: v1.8.0-b19'.

The 'IP Addresses' section contains the following table:

Name	Ip	MAC	Link	Mode
eth0	192.168.11.1	70-B3-05-04-20-80	●	static
eth1	192.168.0.33	70-B3-05-04-20-61	●	static